

SWT



SE ... 10

GB ... 12

Fan heater SWT

1. Fan heater SWT
2. Filter SWTCF
3. Air director SWTCL
4. Extension collar SWTCE

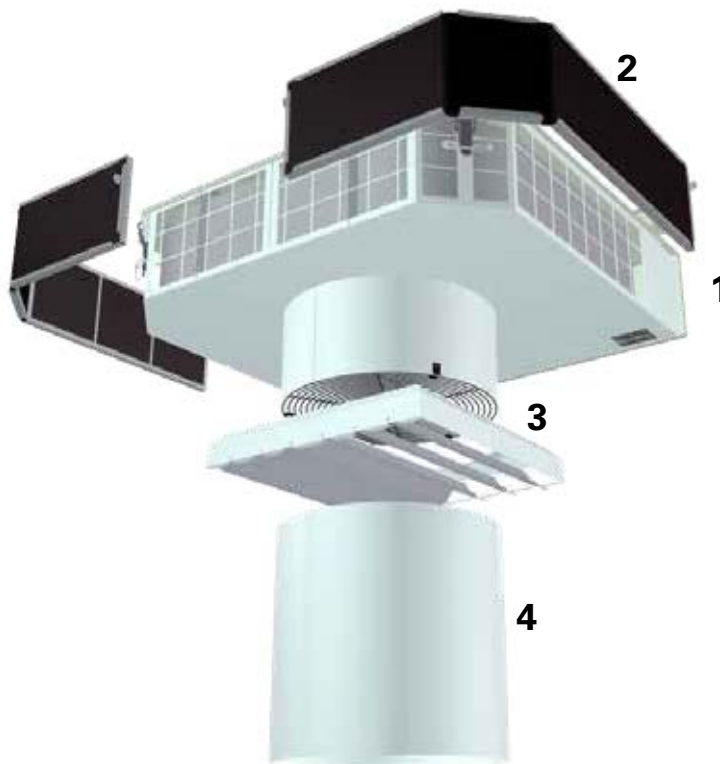

Fig 1: Accessories

Dimensions

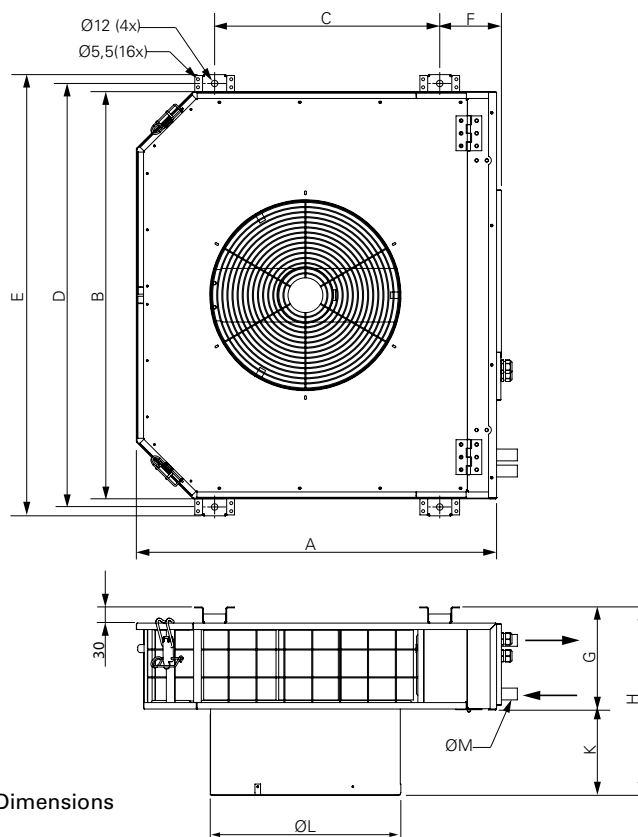

Fig 2: Dimensions

Type	A [mm]	B [mm]	C [mm]	D [mm]	E [mm]	F [mm]	G [mm]	H [mm]	K [mm]	ØL [mm]	ØM [mm]
SWT02	535	640	280	670	705	125	195	330	135	305	22
SWT12	675	760	420	790	825	115	195	355	160	355	22
SWT22	735	1070	480	1100	1135	110	300	415	115	430	28

Mounting

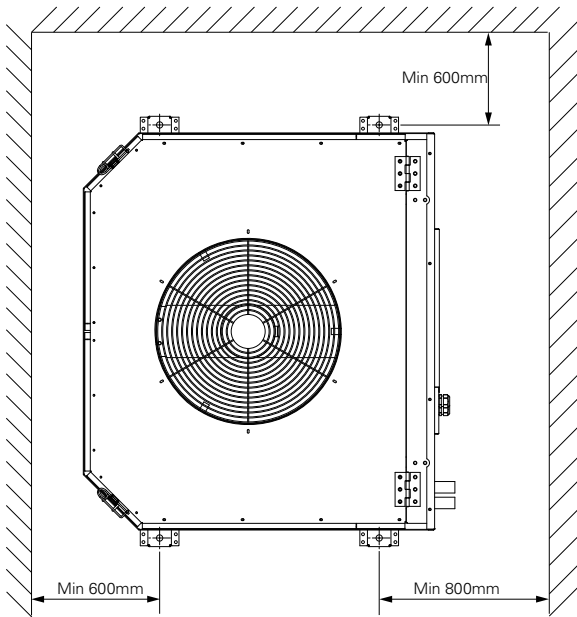

Fig. 3: Minimum mounting distance

Type	A [mm]	B [mm]
SWT02	280	640
SWT12	420	760
SWT22	480	1070

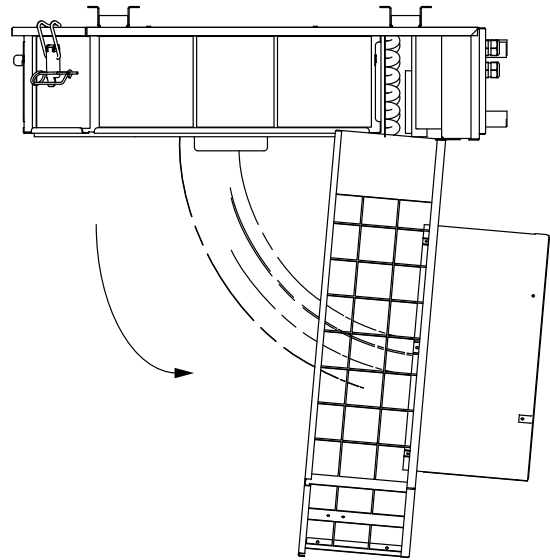

Fig. 4: To open

Air throw

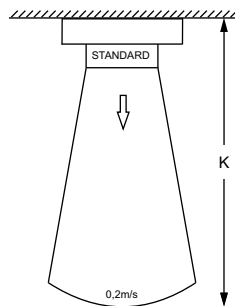

Fig. 5: Without accessories

Type	Fan position	K* - STANDARD [m]
SWT02	high	4,0
	low	2,2
SWT12	high	4,5
	low	2,7
SWT22	high	7,5
	low	4,5

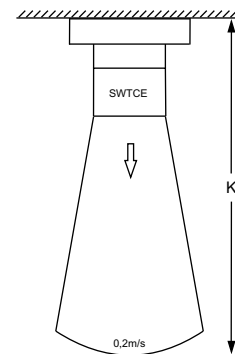
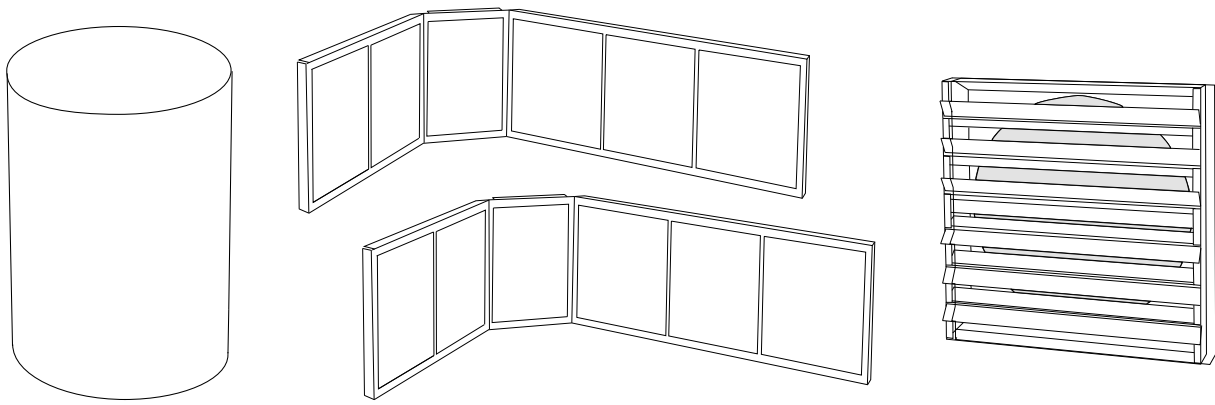

Fig. 6: With accessories

Type	Fan position	K* - SWTC [m]
SWT02	high	7,0
	low	4,0
SWT12	high	8,0
	low	5,0
SWT22	high	12,0
	low	7,0

*) The air throw is defined as the distance in a straight angle from the fan heater to the point where the air speed has dropped to 0,2 m/s. Outlet temperature is +40 °C and room temperature is +18 °C.

Accessories



Type	Description	HxWxD [mm]
SWTCE02	Extension collar 350 mm for SWT02	
SWTCE12	Extension collar 350 mm for SWT12	
SWTCE22	Extension collar 350 mm for SWT22	
SWTCF02	Filter for SWT02 (2 pcs)	
SWTCF12	Filter for SWT12 (2 pcs)	
SWTCF22	Filter for SWT22 (2 pcs)	
SWTCL02	Air director for SWT02	362x362x59
SWTCL12	Air director for SWT12	412x412x67
SWTCL22	Air director for SWT22	482x482x67

Controls

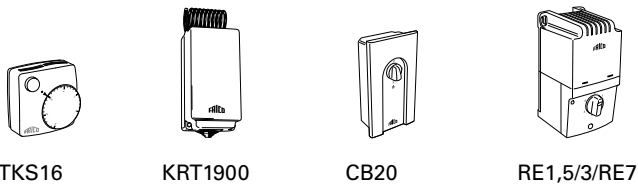

Type	Description	HxWxD [mm]
TKS16	Electronic thermostat with knob and 1-pole main switch	80x80x31
KRT1900	Capillary tube thermostat	165x57x60
CB20	2-step change-over switch for air flow, max 10A	155x87x43
RE1,5	5-step change-over switch for air flow, max. 1,5A	200x105x105
RE3	5-step change-over switch for air flow, max. 3A	200x105x105
RE7	5-step change-over switch for air flow, max. 7A	247x147x145

Water regulation

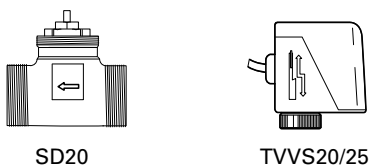

Type	RSK-nr (SE)
SD20	672 70 37
TVVS20	673 92 96
TVVS25	673 92 97

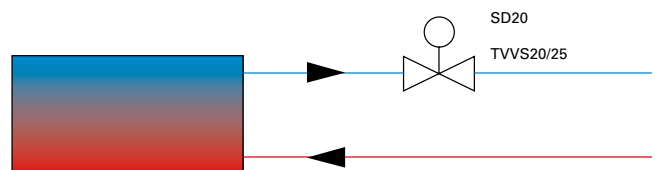

Wiring diagrams SWT

Internal

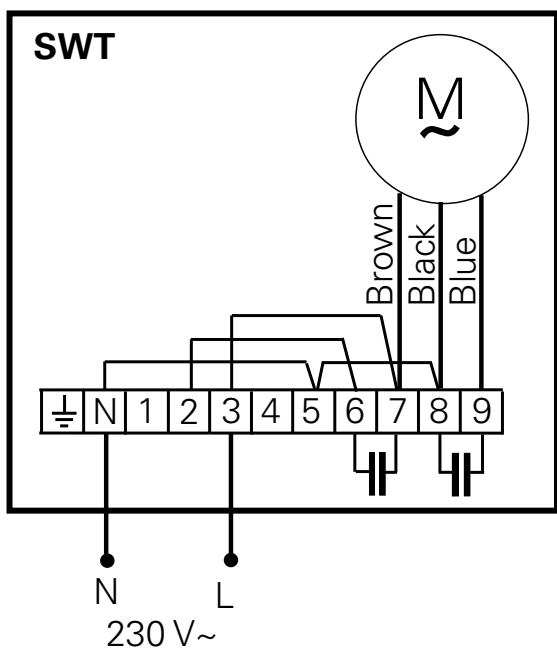

Control by thermostat only

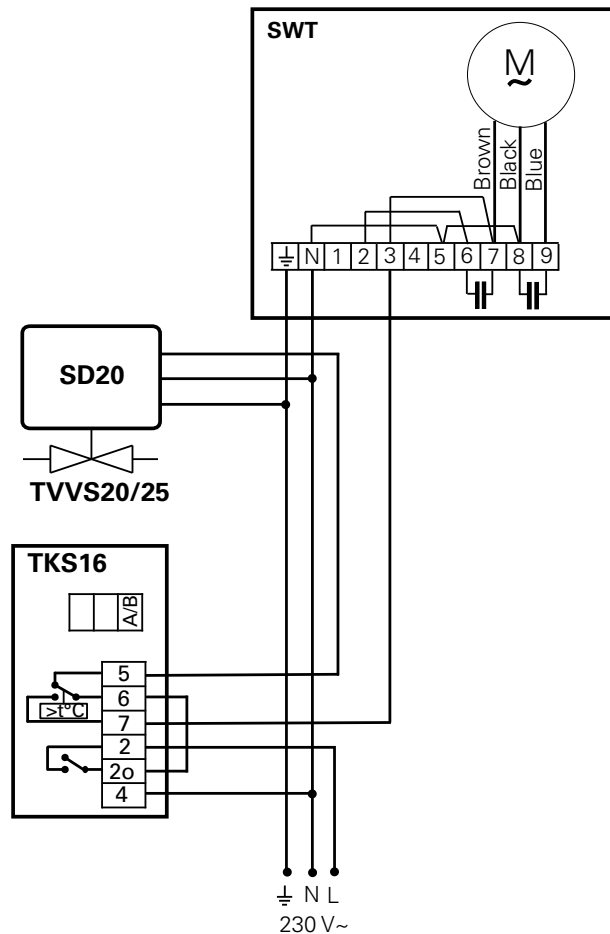
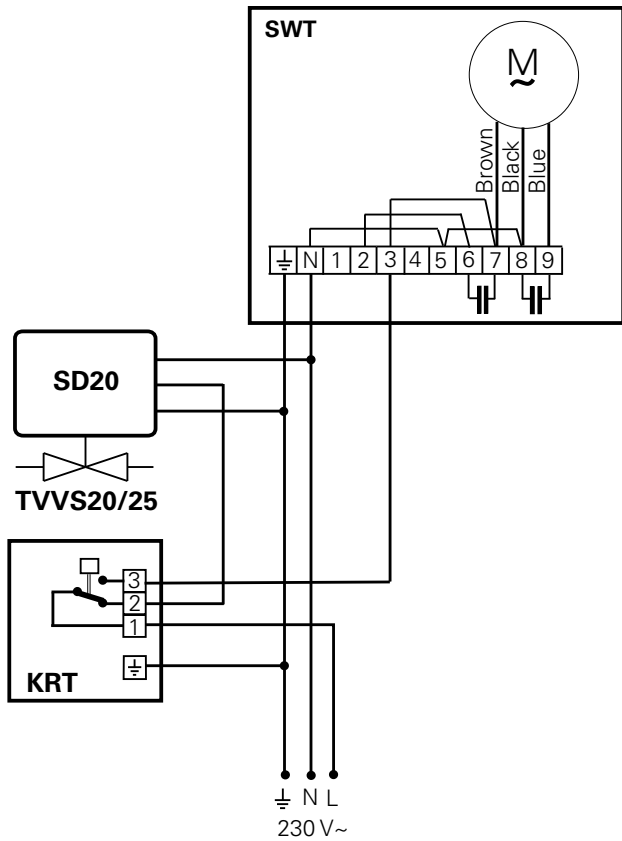

2-step control of airflow only

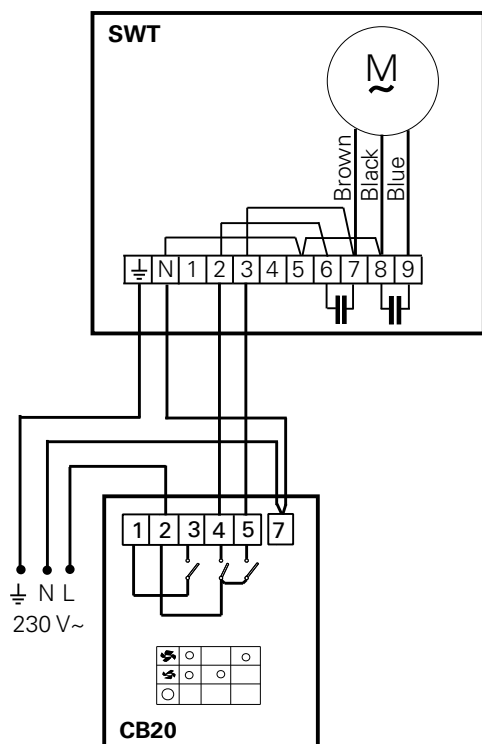

5-step control of airflow only

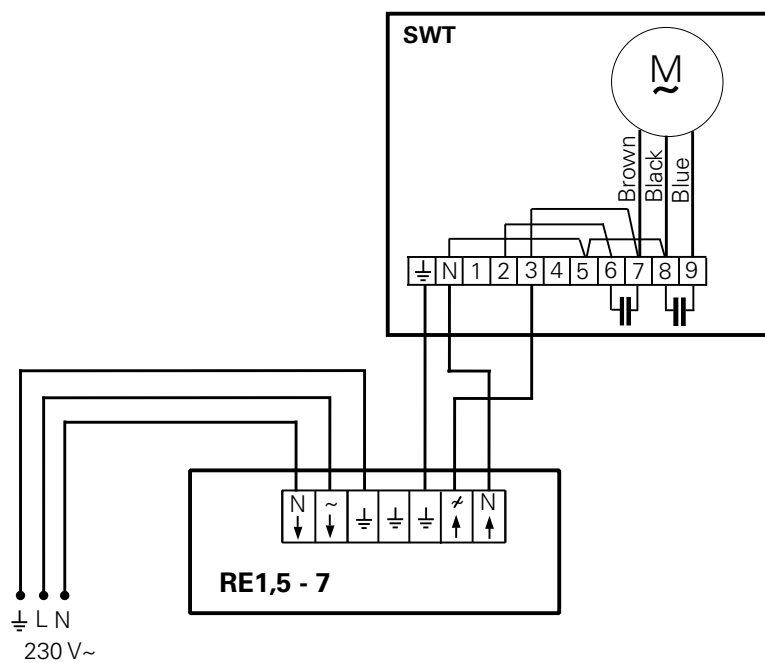

Thermostat and 2-step control

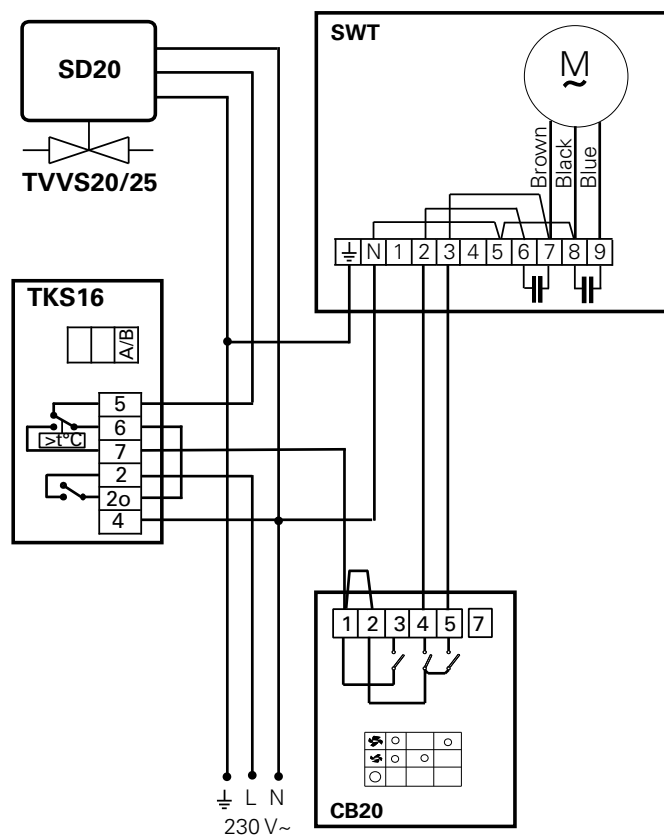
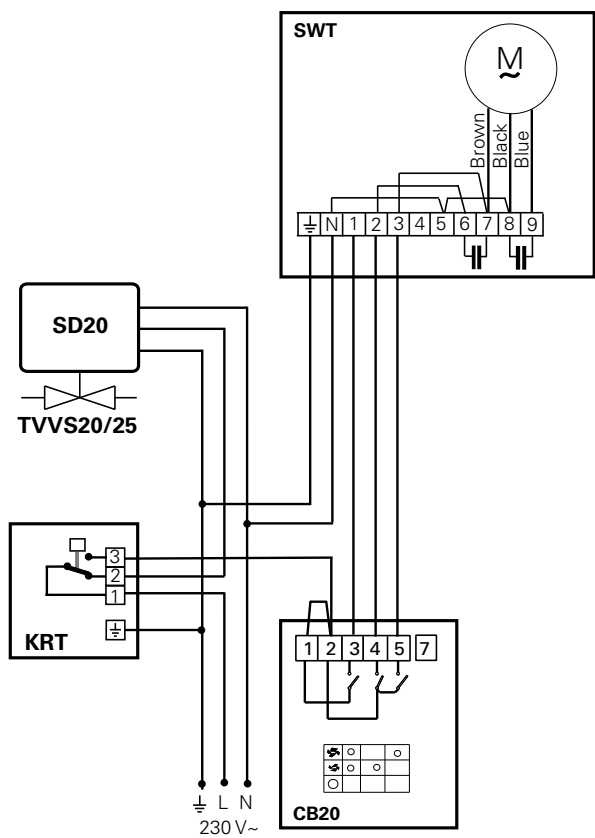

Thermostat and 5-step control

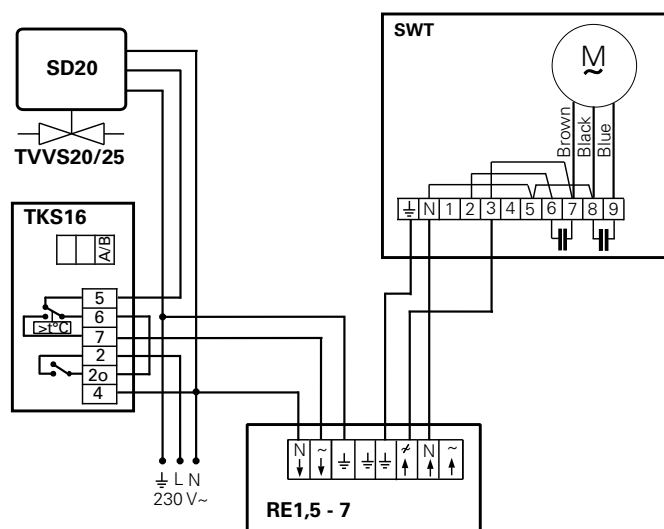
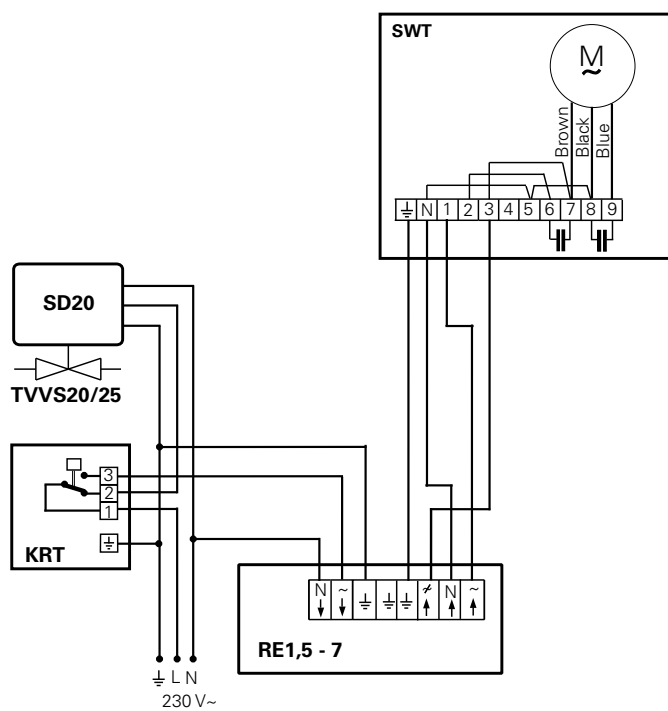

Technical specification | Fan heater SWT

Type	Heat (1) output* ¹ [kW]	Air flow (2) [m ³ /h]	Air flow(2) [m ³ /s]	Sound (3) level* ² [dB(A)]	Δt * ^{1,3} [°C]	Air throw* ⁴ (4a) [m]	Air throw* ⁴ (4b) with extension collar [m]
SWT02	7,8/11	700/1100	0,19/0,31	37/53	33/29	2,2/4	4/7
SWT12	14/18	1300/2000	0,36/0,56	44/57	25/22	2,7/4,5	5/8
SWT22	29/40	2500/3900	0,69/1,08	48/60	34/30	4,5/7,5	7/12

Type	Water (5) volume* ⁵ [l]	Voltage (6) [V]	Amperage (7) [A]	LxWxH (8) [mm]	Weight (9) [kg]	RSK (SE)	NRF (NO)
SWT02	1,2	230V~	0,4	705x535x330	19	672 67 03	850 23 11
SWT12	1,7	230V~	0,6	825x625x355	26	672 67 04	850 23 12
SWT22	3,9	230V~	1,0	1135x735x415	41	672 67 05	850 23 13

*¹) Applicable at water temperature 80/60 °C, air temperature, in +15 °C.

*²) Conditions: Distance to the unit 5 metres.

*³) Δt = temperature rise of passing air at maximum heat output and lowest/highest airflow.

*⁴) The air throw data above is valid when the horizontally adjustable air director is used and the outlet temperature is +40 °C and the room temperature is +18 °C. The air throw is defined as the distance in a straight angle from the fan heater to the the point where the air speed has dropped to 0,2 m/s.

*⁵) Water volume inside battery.

Protection class: (IP44), splash-proof design.
CE compliant.

(1)
SE: Värme effekt
GB: Heat output

(6)
SE: Spänning
GB: Voltage

(2)
SE: Luftflöde
GB: Air flow

(7)
SE: Ström
GB: Amperage

(3)
SE: Ljudnivå
GB: Soud level

(8)
SE: LxBxD
GB: LxWxH

(4a)
SE: Kastlängd
GB: Air distribution

(9)
SE: Vikt
GB: Weight

(4b)
SE: Kastlängd med förlängningsstos
GB: Air distibution with extension sleeve

(5)
SE: Vattenvolym
GB: Water volume

Output charts water

Incoming / outgoing water temperature 80/60 °C

Type	Fan pos.	Air-flow [m ³ /s]	Air temp. in = +10 °C				Air temp. in = +15 °C				Air temp. in = +20 °C			
			Output	Air temp. out. [°C]	Water flow [l/s]	Pressure drop [kPa]	Output	Air temp. out. [°C]	Water flow [l/s]	Pressure drop [kPa]	Output	Air temp. out. [°C]	Water flow [l/s]	Pressure drop [kPa]
			[kW]				[kW]				[kW]			
SWT02	max	0,31	12,0	42	0,15	11,2	10,8	44	0,13	9,3	9,6	46	0,11	7,5
	min	0,19	8,7	46	0,10	6,2	7,8	48	0,09	5,1	6,9	50	0,09	4,1
SWT12	max	0,56	20,3	39	0,25	17,8	18,4	42	0,23	14,8	16,5	44	0,20	12,1
	min	0,36	15,4	44	0,19	10,7	13,9	46	0,17	9,0	12,5	49	0,15	7,4
SWT22	max	1,08	44,0	43	0,53	14,0	39,6	45	0,48	11,5	35,5	47	0,43	9,3
	min	0,69	32,0	47	0,39	7,8	28,9	49	0,35	6,5	25,7	51	0,31	5,2

Incoming / outgoing water temperature 60/40 °C

Type	Fan pos.	Air-flow [m ³ /s]	Air temp. in = +10 °C				Air temp. in = +15 °C				Air temp. in = +20 °C			
			Output	Air temp. out. [°C]	Water flow [l/s]	Pressure drop [kPa]	Output	Air temp. out. [°C]	Water flow [l/s]	Pressure drop [kPa]	Output	Air temp. out. [°C]	Water flow [l/s]	Pressure drop [kPa]
			[kW]				[kW]				[kW]			
SWT02	max	0,31	7,5	30	0,09	4,9	6,4	40	0,08	3,8	5,3	34	0,06	2,7
	min	0,19	5,4	33	0,06	2,8	4,6	34	0,06	2,1	3,8	36	0,05	1,5
SWT12	max	0,56	13,0	29	0,16	8,3	11,1	31	0,13	6,3	9,2	34	0,11	4,4
	min	0,36	9,9	32	0,12	5,1	8,4	34	0,10	3,8	7,0	36	0,09	2,7
SWT22	max	1,08	27,1	30	0,33	5,9	23,2	33	0,28	4,5	19,3	35	0,23	3,2
	min	0,69	19,9	33	0,24	3,4	16,8	35	0,20	2,5	14	37	0,17	1,8

Incoming / outgoing water temperature 55/45 °C

Type	Fan pos.	Air-flow [m ³ /s]	Air temp. in = +10 °C				Air temp. in = +15 °C				Air temp. in = +20 °C			
			Output	Air temp. out. [°C]	Water flow [l/s]	Pressure drop [kPa]	Output	Air temp. out. [°C]	Water flow [l/s]	Pressure drop [kPa]	Output	Air temp. out. [°C]	Water flow [l/s]	Pressure drop [kPa]
			[kW]				[kW]				[kW]			
SWT02	max	0,31	8,1	34	0,20	20,5	6,9	34	0,17	15,4	5,8	36	0,14	11,1
	min	0,19	5,8	34	0,14	11,2	5,0	36	0,12	8,4	4,2	38	0,10	6,1
SWT12	max	0,56	13,6	26	0,33	31,9	11,7	32	0,28	24,3	9,9	34	0,23	16,8
	min	0,36	10,3	30	0,25	19,2	8,8	35	0,21	14,7	7,5	36	0,18	10,1
SWT22	max	1,08	32,1	33	0,71	25,6	25,3	34	0,62	19,1	21,2	37	0,51	13,7
	min	0,69	21,5	35	0,52	14,1	18,4	37	0,45	10,6	15,4	39	0,37	7,6

Assembly and operating instructions

General Instructions

Read these instructions carefully before installation and use. Keep this manual for future reference.

The product may only be used as set out in the assembly and operating instructions. The guarantee is only valid if the product is used in the manner intended and in accordance with the instructions.

Application

Fan heater SWT is a fan heater for water connection.

SWT is used for heating of entrances, storages rooms, industrial premises, workshops, sports arenas, garages and shops.

The fan heater is mounted directly on the ceiling or in drop rods. The low construction height makes SWT suitable for recessed mounting in false ceiling.

Protection class: IP44

The unit consists of the following:

Casing of white powder coated galvanized steel sheet.

The front with hinges can be open for maintenance.

Fan unit

Motor with ball bearing and thermal protection. Protection class IP44. Maximum surrounding temperature: +40 °C.

Water heating coil

Heating coil with aluminium fins and copper tubes. Connections SWT01 and SWT12 Ø22 and SWT22 Ø28.

In standard designs, SWT is intended for hot water up +80 °C and 10 bar. The heating coils are pressure tested for 15 bar.

Mounting

The unit is delivered with casing, brackets, fan and heating coil as standard. If several fan heaters are installed in the same premises, ensure that they are uniformly distributed and that they deliver air so that the working environment will not be disturbed.

The fan heater is mounted directly on the

ceiling or in drop rods. Secure the fan heater to the ceiling with four screws through the brackets. Drop rods are used when mounting at a distance from ceiling. For drilling template, see fig. 2 and fig. 3.

If the ceiling structure is weak, it must be reinforced to ensure safe installation. For particulars of weights of each size, see table p. 8.

Mounting of the extension collar SWTCE

If the fan heater is mounted at a high level, the outlet collar of the SWT can be replaced by a longer collar. This increases the air throw of the fan heater, see fig. 6.

Mount the extension collar on the outlet collar.

Mounting of the air director SWTCL

To avoid draught in cases of low installations, air directors can be mounted to get a better direction of the air sideways.

Mount the air director on the outlet collar

Mounting of the filter SWTCF

When filter is mounted the intervals for cleaning the water coil increases.

Loosen the clamps on the fan plate and let it hang down. Now hook the two hooks on the filter into the grid.

Connection of heating coil

The installation should be carried out by a certified installer. The water inlet is connected to the heaters lowest pipe and the outlet, with or without valve, to the highest placed pipe. For correct inlet and outlet connection, see dimension sketch fig.2. Be careful while connecting the pipes to prevent pipe damage and water leakage.

The heating coil must not be connected to a mains pressure water system or an open water system.

Prior to use, the pipe system should be ventilated. The air valve should be connected on a high point in the pipe system. Air and draining valves are not included in the heating coil.

Units that are likely to be exposed to air

temperatures below zero should be equipped with external frost protection to ensure that the heating coil is not damaged by frost.

Electrical installation

The electrical installation should be carried out by a qualified electrician in conformity with prevailing regulations. The appliance should be preceded by an triple-pole switch with at least 3 mm breaking gap.

Fan heater SWT is intended for fixed installation and is connected by knock-outs on the heaters back side.

The motor has a built-in thermal safety cut-out to protect against overheating. This will reset automatically once the motor has cooled.

Cable glands used must guarantee the protection class requirements.

After the electrical installation of the motor, check the rotation of the fan. Seen from the inlet side, the impellers should be rotating anti-clockwise.

See wiring diagrams.

Start-up

When the unit is used for the first time or after a long period of disuse, smoke or odour may result from dust or dirt that has collected on the element. This is completely normal and disappears after a short time.

Maintenance

To ensure performance and reliability of the unit, inspection and cleaning should be carried out regularly. Inspection should be carried out at least twice a year. Clean the unit when needed. During inspection the power supply must always be disconnected.

Cleaning the fan

Cleaning intervals of the fan is due to filter (if any) and air quality.

To ensure performance and reliability of the unit, inspection and cleaning should be carried out regularly. Inspection should be carried out at least twice a year. Clean the unit when needed. During inspection the power supply must always be disconnected.

If the impellers are not cleaned properly, vibrations/noise can occur and severely

damage the bearings. If the vibrations/noise remain after cleaning, please contact a certified technician.

Loosen the clamps on the fan plate and let it hang down. Use compressed air from the inside out to clean the water coil. Use a soft brush to clean the impellers. If water or steam is used for cleaning, ensure that the motor is protected from water.

Safety

- *Ensure that the area around the intake is kept free from material which could prevent the air flow through the appliance!*
- *The appliances have hot surfaces during operation!*
- *This appliance can be used by children aged from 8 years and above and persons with reduced physical, sensory or mental capabilities or lack of experience and knowledge if they have been given supervision or instruction concerning use of the appliance in a safe way and understand the hazards involved. Children shall not play with the appliance. Cleaning and user maintenance shall not be made by children without supervision.*
- *Lifting aids should be used to lift the appliance.*



Main office

Frico AB
Box 102
SE-433 22 Partille
Sweden

Tel: +46 31 336 86 00
mailbox@frico.se
www.frico.se

**For latest updated information and information
about your local contact: www.frico.se**