

technical data



Fan coil units

FWB-J - Duct unit

FWB-J - Duct unit

In all of us,
a green heart



Daikin's unique position as a manufacturer of air conditioning equipment, compressors and refrigerants has led to its close involvement in environmental issues. For several years Daikin has had the intension to become a leader in the provision of products that have limited impact on the environment. This challenge demands the eco design and development of a wide range of products and an energy management system, resulting in energy conservation and a reduction of waste.



Daikin Europe N.V. is approved by LRQA for its Quality Management System in accordance with the ISO9001 standard. ISO9001 pertains to quality assurance regarding design, development, manufacturing as well as to services related to the product.

The present publication is drawn up by way of information only and does not constitute an offer binding upon Daikin Europe N.V. Daikin Europe N.V. has compiled the content of this publication to the best of its knowledge. No express or implied warranty is given for the completeness, accuracy, reliability or fitness for particular purpose of its content and the products and services presented therein. Specifications are subject to change without prior notice. Daikin Europe N.V. explicitly rejects any liability for any direct or indirect damage, in the broadest sense, arising from or related to the use and/or interpretation of this publication. All content is copyrighted by Daikin Europe N.V..



ISO14001 assures an effective environmental management system in order to help protect human health and the environment from the potential impact of our activities, products and services and to assist in maintaining and improving the quality of the environment.



Daikin units comply with the European regulations that guarantee the safety of the product.



Daikin Europe N.V. participates in the Eurovent Certification Programme for Air Conditioners (AC), Liquid Chilling Packages (LCP) and Fan Coil Units (FC); the certified data of certified models are listed in the Eurovent Directory.

Specifications are subject to change without prior notice

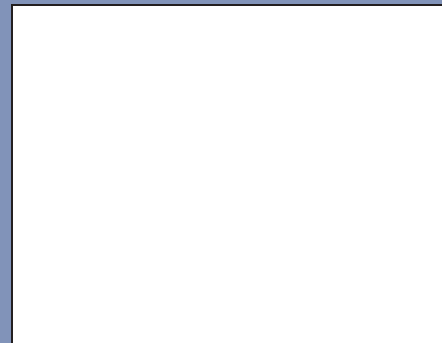

DAIKIN EUROPE N.V.

Naamloze Vennootschap
Zandvoordestraat 300
B-8400 Oostende, Belgium
www.daikin.eu
BTW: BE 0412 120 336
RPR Oostende



EEDEN07-431

technical data

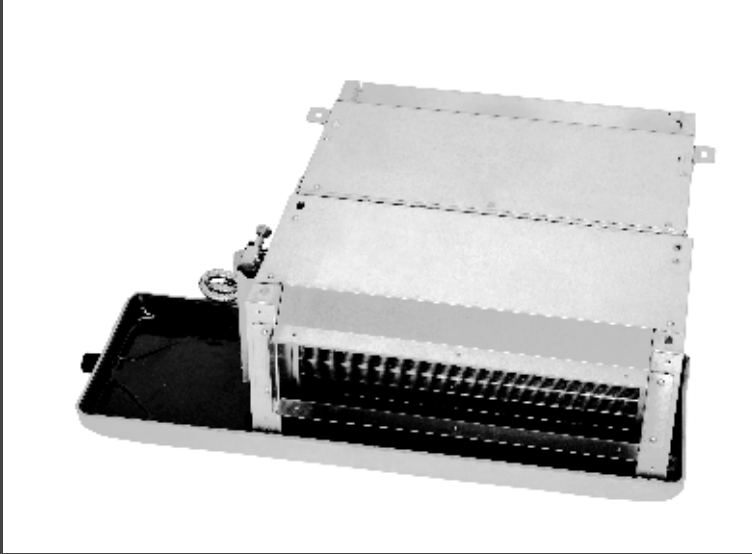

Fan coil units

FWB-J - Duct Unit

Cooling only



Heating only

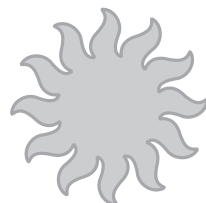

Heat pump



TABLE OF CONTENTS

FWB-J

1	Features	4
2	Specifications	5
	Nominal capacity and nominal input	5
	Technical Specifications	6
	Electrical Specifications	8
3	Nomenclature	10
4	Options	11
5	Control systems	13
6	Capacity tables	14
	Capacity tables with glycol for process cooling applications	14
7	Dimensional drawing & centre of gravity	15
	Dimensional drawing	15
8	Wiring diagram	16
	Wiring diagram	16
9	Sound data	17
	Sound pressure spectrum	17
	Sound power spectrum	18
10	Operation range	19
11	Hydraulic performance	20
	Water pressure drop curve evaporator	20

1 Features

- Wide operating range
- Quiet operation via enlarged fan wheels
- Easy maintenance: filter can be removed from both sides and beneath (maximum filter size is 400mm)
- Flexibility (2-pipe or 4-pipe)
- 4 speed fan motor (3 selectable)
- Direct driven centrifugal fans
- Flexibility via interchangeable water connection side
- High power air flow
- Slim and compact aesthetic design
- Available static pressure of 30 Pa
- Extended drain pan as standard
- Filter as standard
- Plenum as standard
- Insulated with self-extinguishing class 1 heat insulation
- Electronic room thermostat

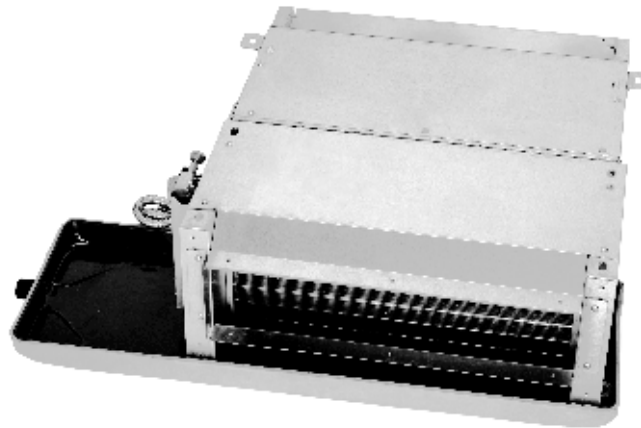

2 Specifications

2-1 NOMINAL CAPACITY AND NOMINAL INPUT			FWB02JT	FWB03JT	FWB04JT	FWB05JT	FWB06JT	FWB07JT	FWB08JT	FWB09JT	
Power Input	Superhigh		W	41	61	76	73	106	144	140	157
	High		W	34	53	57	54	86	121	117	134
	Medium		W	29	48	51	48	75	109	106	121
	Low		W	25	45	47	44	68	100	98	113
Cooling capacity	Total capacity	Superhigh	kW	2.18	3.10	4.13	4.59	5.79	6.42	7.56	8.55
		High	kW	1.64	2.67	2.99	3.34	4.81	5.31	6.16	7.26
		Medium	kW	1.42	2.31	2.43	2.67	4.02	4.48	5.13	6.24
		Low	kW	1.21	2.14	1.96	2.11	3.37	3.90	4.29	5.38
	Sensible capacity	Superhigh	kW	1.38	2.27	2.94	3.08	4.22	5.21	5.54	6.08
		High	kW	0.94	1.88	1.95	2.07	3.40	4.15	4.39	5.06
		Medium	kW	0.91	1.55	1.50	1.57	2.75	3.42	3.61	4.25
		Low	kW	0.78	1.35	1.14	1.20	2.22	2.89	2.98	3.57
Heating capacity (2-pipe)	Superhigh		kW	2.94	4.32	5.71	5.92	7.69	9.15	10.09	11.52
	High		kW	2.16	3.62	3.97	4.11	6.30	7.47	8.09	9.64
	Medium		kW	1.92	3.13	3.15	3.34	5.15	6.30	6.78	8.20
	Low		kW	1.64	2.74	2.44	2.65	4.23	5.38	5.77	7.01

2-1 NOMINAL CAPACITY AND NOMINAL INPUT			FWB10JT	FWB11JT	FWB02JF	FWB03JF	FWB04JF	FWB06JF	FWB07JF	FWB08JF	
Power Input	Superhigh		W	201	203	40	58	74	103	141	160
	High		W	164	166	34	51	54	84	117	137
	Medium		W	145	147	28	47	48	74	106	124
	Low		W	132	135	24	44	45	67	99	115
Cooling capacity	Total capacity	Superhigh	kW	9.84	10.66	2.18	3.10	4.09	5.70	6.41	7.40
		High	kW	8.49	8.99	1.67	2.67	3.03	4.88	5.33	6.53
		Medium	kW	7.27	7.74	1.43	2.35	2.42	4.20	4.55	5.71
		Low	kW	6.27	6.68	1.19	2.07	1.98	3.60	3.92	5.02
	Sensible capacity	Superhigh	kW	7.65	7.82	1.36	2.22	2.85	4.16	5.05	5.84
		High	kW	6.37	6.41	0.97	1.83	1.93	3.41	4.01	4.91
		Medium	kW	5.26	5.30	0.89	1.56	1.46	2.81	3.32	4.18
		Low	kW	4.38	4.48	0.75	1.34	1.12	2.34	2.77	3.58
Heating capacity (2-pipe)	Superhigh		kW	13.73	14.13	2.86	4.37	5.44	7.66	9.31	10.59
	High		kW	11.57	11.71	2.12	3.69	3.87	6.40	7.52	9.01
	Medium		kW	9.61	9.79	1.84	3.23	2.97	5.32	6.26	7.79
	Low		kW	8.13	8.31	1.56	2.88	2.40	4.52	5.32	6.84
Heating capacity (4-pipe)	Superhigh		kW			3.07	4.48	5.69	7.66	9.50	10.74
	High		kW			2.49	3.92	4.43	6.70	8.16	9.56
	Medium		kW			1.99	3.57	3.67	5.88	7.12	8.62
	Low		kW			1.68	3.26	3.04	5.25	6.34	7.86

2-1 NOMINAL CAPACITY AND NOMINAL INPUT			FWB10JF	
Power Input	Superhigh		W	200
	High		W	163
	Medium		W	145
	Low		W	133
Cooling capacity	Total capacity	Superhigh	kW	9.59
		High	kW	8.21
		Medium	kW	7.04
		Low	kW	6.08
	Sensible capacity	Superhigh	kW	7.60
		High	kW	6.28
		Medium	kW	5.23
		Low	kW	4.37
Heating capacity (2-pipe)	Superhigh		kW	13.32
	High		kW	11.09
	Medium		kW	9.36
	Low		kW	7.97

2 Specifications

1
2

2-1 NOMINAL CAPACITY AND NOMINAL INPUT			FWB10JF			
Heating capacity (4-pipe)	Superhigh	kW	13.15			
	High	kW	11.68			
	Medium	kW	10.30			
	Low	kW	9.15			

2-2 TECHNICAL SPECIFICATIONS				FWB02JT	FWB03JT	FWB04JT	FWB05JT	FWB06JT	FWB07JT	FWB08JT	FWB09JT
Dimensions	Unit	Height	mm	251	251	251	251	251	251	251	251
		Width	mm	814	984	1,114	1,114	1,314	1,564	1,564	1,664
		Depth	mm	590	590	590	590	590	590	590	590
	Unit with packing	Height	mm	254	254	254	254	254	254	254	254
		Width	mm	824	994	1,124	1,124	1,324	1,574	1,574	1,674
		Depth	mm	600	600	600	600	600	600	600	600
Weight	Machine weight	kg	20.0	23.0	28.0	31.0	33.0	44.0	48.0	52.0	
	Operation weight	kg	20.7	24.0	29.1	32.5	34.4	45.8	50.4	54.6	
	Gross weight	kg	22.8	26.4	31.6	34.6	37.2	48.9	52.9	57.4	
Material				Galvanised sheet metal							
Sound level	Sound pressure	Superhigh	dB(A)	38	42	41	41	43	43	43.5	45.5
		High	dB(A)	35.5	40	37	38	40	40	39.5	43
		Medium	dB(A)	32	37	33	34	38	38	38	41
		Low	dB(A)	31	35	32	32.5	35.5	36	36	39
	Sound power	Superhigh	dB(A)	51.5	55	54.5	55	56	56	57	59
		High	dB(A)	47.5	52	49	50	52	52	52	55
		Medium	dB(A)	43	48	43.5	45	48.5	48.5	49	52
		Low	dB(A)	41	45.5	42.5	43	46	46	46	49
Water flow	Cooling	l/h	386	549	739	803	1,022	1,109	1,383	1,523	
	Heating	l/h	386	549	738	802	1,020	1,107	1,336	1,524	
Water pressure drop	Cooling	kPa	10.91	8.34	15.64	11.22	31.31	12.56	7.62	9.83	
	Heating	kPa	8.86	6.76	12.84	9.21	25.87	11.13	6.57	8.60	
Fan	Type	Direct driven centrifugal fan (forward-curved blades); hot-galvanised steel									
	Air flow rate	Superhigh	m ³ /h	331	548	715	667	982	1,241	1,238	1,323
		High	m ³ /h	262	428	431	428	757	945	950	1,066
		Medium	m ³ /h	219	357	323	325	596	756	764	882
		Low	m ³ /h	187	304	248	255	476	628	633	733
	Available pressure	High	Pa	30	30	30	30	30	30	30	30
	Speed	4 steps: super high, high, medium, low									
Quantity				1	1	2	2	2	3	3	3
Motor	Type	Single phase capacitor running									
Standard heat exchanger	Rows	mm	3	3	3	4	3	3	4	4	
	Stages	mm	2	3	3	4	3	6	8	8	
	Fin pitch	mm	2.3	2.3	2.3	2.3	2.3	2.3	2.3	2.3	
	Face area	m ²	0.09	0.13	0.15	0.15	0.19	0.24	0.24	0.26	
	Water volume	l	0.69	0.95	1.14	1.52	1.44	1.82	2.42	2.62	
Air filter	Washable Nylon in 8mm Aluminium frame										
Insulation material	PE										
Water connections	Std. heat exchanger	inch	3/4								
Drain		mm	714	884	1014	1014	1214	1464	1464	1564	
Notes	Rating conditions cooling 2 pipe: air 27										
	Rating conditions heating 2 pipe: air 21×C DB - entering water 60×C										
	Sound pressure level according to GB/T 19232 Fan-coil unit (national standard)										
	Sound pressure measured at 1m in front of the unit and 1m below the vertical centre line of the unit										

2-2 TECHNICAL SPECIFICATIONS				FWB10JT	FWB11JT	FWB02JF	FWB03JF	FWB04JF	FWB06JF	FWB07JF	FWB08JF
Dimensions	Unit	Height	mm	251	251	251	251	251	251	251	251
		Width	mm	1,924	1,924	814	984	1,114	1,314	1,564	1,664
		Depth	mm	590	590	590	590	590	590	590	590
	Unit with packing	Height	mm	254	254	254	254	254	254	254	254
		Width	mm	1,934	1,934	824	994	1,124	1,324	1,574	1,674
		Depth	mm	600	600	600	600	600	600	600	600

2 Specifications

2-2 TECHNICAL SPECIFICATIONS			FWB10JT	FWB11JT	FWB02JF	FWB03JF	FWB04JF	FWB06JF	FWB07JF	FWB08JF	
Weight	Machine weight	kg	50.0	56.0	22.0	27.0	31.0	36.0	48.0	52.0	
	Operation weight	kg	52.4	59.1	22.9	28.3	32.5	37.9	50.4	54.6	
	Gross weight	kg	55.9	61.9	24.8	30.4	34.6	40.2	52.9	57.4	
Material			Galvanised sheet metal								
Sound level	Sound pressure	Superhigh	dBA	46	46.5	38	42	41	43	43.5	45.5
		High	dBA	43.5	44	35	40	38	40	39.5	43
		Medium	dBA	41	41.5	33	37	34	38	38	41
		Low	dBA	39	39.5	31	35	32.5	35.5	36	39
	Sound power	Superhigh	dBA	59.5	60	52	55	55	56	57	59
		High	dBA	55.5	56	47	52	50	52	52	55
		Medium	dBA	51.5	52	44	48	45	49	49	52
Low		dBA	49.5	50	41	46	43	46	46	49	
Water flow	Cooling	l/h	1,764	1,910	386	530	724	986	1,138	1,296	
	Heating	l/h	1,764	1,911	387	530	725	985	1,139	1,299	
	Add. heat exchanger	l/h			269	391	493	663	820	924	
Water pressure drop	Cooling	kPa	21.71	16.81	10.95	8.24	15.67	29.95	9.24	12.49	
	Heating	kPa	18.56	14.46	8.94	6.64	12.84	24.16	7.89	9.67	
	Add. heat exchanger	kPa			10.66	24.73	41.72	81.63	25.31	31.33	
Fan	Type		Direct driven centrifugal fan (forward-curved blades); hot-galvanised steel								
	Air flow rate	Superhigh	m ³ /h	1,837	1,695	327	526	684	944	1,200	1,379
		High	m ³ /h	1,463	1,341	220	424	437	747	898	1,112
		Medium	m ³ /h	1,171	1,210	218	350	326	597	737	920
		Low	m ³ /h	946	1,093	184	301	251	489	599	777
	Available pressure	High	Pa	30	30	30	30	30	30	30	30
	Speed		4 steps: super high, high, medium, low								
Quantity		4	4	1	1	2	2	3	3		
Motor	Type		Single phase capacitor running								
Standard heat exchanger	Rows	mm	3	4	4 (3+1)	4 (3+1)	4 (3+1)	4 (3+1)	4 (3+1)	4 (3+1)	
	Stages	mm	6	8	2	3	3	3	6	6	
	Fin pitch	mm	2.3	2.3	2.3	2.3	2.3	2.3	2.3	2.3	
	Face area	m ²	0.32	0.32	0.09	0.13	0.15	0.19	0.24	0.26	
	Water volume	l	2.36	3.14	0.92	1.26	1.52	1.92	2.42	2.62	
Additional heat exchanger	Stages	mm			2	2	2	2	4	4	
	Fin pitch	mm			2.3	2.3	2.3	2.3	2.3	2.3	
	Face area	m ²			0.09	0.13	0.15	0.19	0.24	0.26	
Air filter	Washable Nylon in 8mm Aluminium frame										
Insulation material	PE										
Water connections	Std. heat exchanger	inch	3/4								
Drain		mm	1824	1824	714	884	1014	1214	1464	1564	
Notes	Rating conditions cooling 2 pipe: air 27										
	Rating conditions heating 2 pipe: air 21×C DB - entering water 60×C										
	Sound pressure level according to GB/T 19232 Fan-coil unit (national standard)										
	Sound pressure measured at 1m in front of the unit and 1m below the vertical centre line of the unit										

2-2 TECHNICAL SPECIFICATIONS			FWB10JF								
Dimensions	Unit	Height	mm	251							
		Width	mm	1,924							
		Depth	mm	590							
	Unit with packing	Height	mm	254							
		Width	mm	1,934							
		Depth	mm	600							
Weight	Machine weight	kg	56.0								
	Operation weight	kg	59.1								
	Gross weight	kg	61.9								
Material	Galvanised sheet metal										

2 Specifications

1
2

2-2 TECHNICAL SPECIFICATIONS				FWB10JF	
Sound level	Sound pressure	Superhigh	dBA	46.5	
		High	dBA	44	
		Medium	dBA	41.5	
		Low	dBA	39.5	
	Sound power	Superhigh	dBA	60	
		High	dBA	56	
		Medium	dBA	52	
		Low	dBA	50	
Water flow	Cooling		l/h	1,660	
	Heating		l/h	1,660	
	Add. heat exchanger		l/h	1,142	
Water pressure drop	Cooling		kPa	19.38	
	Heating		kPa	16.50	
	Add. heat exchanger		kPa	50.03	
Fan	Type	Direct driven centrifugal fan (forward-curved blades); hot-galvanised steel			
	Air flow rate	Superhigh	m ³ /h	1,738	
		High	m ³ /h	1,385	
		Medium	m ³ /h	1,115	
		Low	m ³ /h	916	
	Available pressure	High	Pa	30	
	Speed	4 steps: super high, high, medium, low			
Quantity	4				
Motor	Type	Single phase capacitor running			
Standard heat exchanger	Rows		mm	4 (3+1)	
	Stages		mm	8	
	Fin pitch		mm	2.3	
	Face area		m ²	0.32	
	Water volume		l	3.14	
Additional heat exchanger	Stages		mm	4	
	Fin pitch		mm	2.3	
	Face area		m ²	0.32	
Air filter	Washable Nylon in 8mm Aluminium frame				
Insulation material	PE				
Water connections	Std. heat exchanger		inch	3/4	
Drain			mm	1824	
Notes	Rating conditions cooling 2 pipe: air 27				
	Rating conditions heating 2 pipe: air 21×C DB - entering water 60×C				
	Sound pressure level according to GB/T 19232 Fan-coil unit (national standard)				
	Sound pressure measured at 1m in front of the unit and 1m below the vertical centre line of the unit				

2-3 ELECTRICAL SPECIFICATIONS			FWB02JT	FWB03JT	FWB04JT	FWB05JT	FWB06JT	FWB07JT	FWB08JT	FWB09JT
Current input	Superhigh	A	0.19	0.28	0.35	0.33	0.48	0.65	0.64	0.71
	High	A	0.15	0.24	0.26	0.25	0.39	0.55	0.53	0.61
	Medium	A	0.13	0.22	0.23	0.22	0.34	0.50	0.48	0.55
	Low	A	0.11	0.20	0.21	0.20	0.31	0.45	0.45	0.51
Required power supply	V / f / Hz	220-240 / 1 / 50								
Required fuses	A	3	3	3	3	3	3	3	3	3
Required wire section	mm ²	1	1	1	1	1	1	1	1	1
2-3 ELECTRICAL SPECIFICATIONS			FWB10JT	FWB11JT	FWB02JF	FWB03JF	FWB04JF	FWB06JF	FWB07JF	FWB08JF
Current input	Superhigh	A	0.91	0.92	0.18	0.26	0.34	0.47	0.64	0.73
	High	A	0.75	0.75	0.15	0.23	0.25	0.38	0.53	0.62
	Medium	A	0.66	0.67	0.13	0.21	0.22	0.34	0.48	0.56
	Low	A	0.60	0.61	0.11	0.20	0.20	0.30	0.45	0.52
Required power supply	V / f / Hz	220-240 / 1 / 50								
Required fuses	A	3	3	3	3	3	3	3	3	3
Required wire section	mm ²	1	1	1	1	1	1	1	1	1

2 Specifications

2-3 ELECTRICAL SPECIFICATIONS			FWB10JF
Current input	Superhigh	A	0.91
	High	A	0.74
	Medium	A	0.66
	Low	A	0.60
Required power supply	V / f / Hz		220-240 / 1 / 50
Required fuses	A		3
Required wire section	mm ²		1

3 Nomenclature

1
3

FWB-J (Nomenclature)

Digit	1	2	3	4	5	6	7	8	9	10	11	12	13	14	15
	F	W	B	0 1	0 1 2 3 4 5 6 7 8 9	A C J K	A B	S T U V W E F G H L	N T V D	6 M C	V	1 3 A L J	- E F G	- E F M P Q R	- R S T
													Options		

Digit	Character	Description	Digit	Character	Description
1-2	FW	Water fancoil	11-12		Power supply
3	V	Type: Vertical		V1	220-240V - 1 phase
	L	Flexi casing		V3	230V - 1 phase
	M	Flexi no casing		VA	220-240V - 1 phase - 60 Hz
	B	Medium ESP duct		VL	220V - 1 phase - 60 Hz
	D	Duct		VJ	208 - 230V - 1 phase - 60 Hz
	T	Wall mounted	13		Electric heater / fan stop thermostat
	C	Cassette		-	No heater / no fan stop thermostt
	F	60x60 cassette		E	Electric heater
4-5	01->18	Size		F	Fan stop thermostat
6	A/C/J/K	Series		G	Electric heater / fan stop thermostat
7	A,...	Minor model change	14		Controller
8		Coil type:		-	No controller
	S	Coil type: 2-pipe 12 Pa		E	electr. contr.
	T	Coil type: 2-pipe standard ESP		F	electr. contr. with network
	U	Coil type: 2-pipe 60 Pa		M	electro mech. contr.
	V	Coil type: 2-pipe 80 Pa		P	Power interface
	W	Coil type: 2-pipe 50 Pa		Q	P+E
	E	Coil type: 4-pipe 12 Pa		R	P+M
	F	Coil type: 4-pipe standard ESP	15		Water connection
	G	Coil type: 4-pipe 60 Pa		-	LL
	H	Coil type: 4-pipe 80 Pa		R	RR
	L	Coil type: 4-pipe 50 Pa		S	RL
9		Valves		T	LR
	N	without valves		A	left connection with horizontal drip tray
	T	with 2-way valves		B	right connection with horizontal drip tray
	V	with 3-way valves		D	right connection with vertical drip tray
	D	with simplified 3-way valves			
10	6	Italy			
	C	China			
	M	Malaysia			

FWB-J

VALVES KIT

The 3-way motorized ON/OFF valve kit, connected to the Daikin controllers, permits to set the room temperature by cutting off the water flow to the heat exchanger.

The kit is available in various fittings for all FWB units, both for 2-pipe and for 4-pipe systems.

The KIT Consist Of

- **3-way valve body with 4 connections** with built-in by-pass made of brass, maximum working pressure 16 bar.
- **Electro thermal actuator** having the following specifications:
 - power supply: 220-240 V,
 - activation: ON/OFF,
 - total opening time: 4 minutes.
- **Hydraulic kit** for the installation of the valve on the heat exchanger, complete with 2 regulating valves for adjusting the water flow and for closing the water circuit when performing maintenance to the unit.
- **Bushing** for routing the cables of the actuator inside the unit.

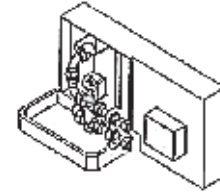

Valve Kit for 2-Pipe system

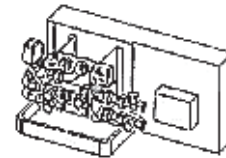

Valve Kit for 4-Pipe system

Thermal insulation to prevent condensation on the valve kit when it operates in cooling mode (only the valve of the standard heat exchanger can work in cooling mode).

The flow resistance of the connecting valve/hydraulic kit assembly is obtained from the following formula:

$$P_w = (Q_w/K_v)^2$$

Where:

P_w is the flow resistance expressed in kg/cm^2

Q_w is the water flow rate expressed in m^3/h

K_v is the flow rate identified in the table

Valve	K_v Direct Passage	K_v By-Pass
1/2"	1.7	1.2
3/4"	2.8	1.8

4 Options

FWB-J

ELECTRONIC THERMOSTAT EC8100A + REMOTE CONTROL RC8100A

Location	Wall Mounted
----------	--------------

Parameters	On/Off
	Temperature
	Fan Speed
	Auto Fan Speed selection
	Date / Time setting
	Mode

Main Functions	Selectable Temperature Operation range: 16-30°C
	Automatic re-start with memory settings
	Heating/Cooling change-over based on system control input
	Auto-diagnosis
	Automatic On/Off setting for each day in a week
	Air sensor control
	2 or 3 ways Valves with ON/OFF control
	Remote control – max. distance: 2.5 meters

ELECTRONIC THERMOSTAT EC8100A

- 1 On/Off key
- 2 Heating/Cooling mode key
- 3 Clock/Timer setting
- 4 Fan Speed selection key (HIGH/MEDIUM/LOW/AUTO)
- 5 Temperature up key
- 6 Temperature down key
- 7 Back-light LCD Display

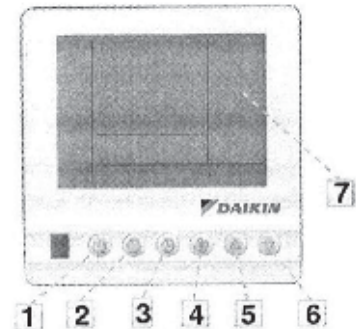

REMOTE CONTROL RC8100A

- a On/Off key
- b Fan Speed selection key (HIGH/MEDIUM/LOW/AUTO)
- c Temperature up key
- d Temperature down key
- e Heating/Cooling mode key

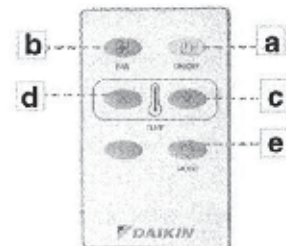

5 Control systems

Control systems for FWB-J

Controller	Application	Operation mode		Basic Controls			Timer setting
		Manual	Automatic	Temperature setting	Automatic Fan Speed	Fan speed: high/medium/low	ON/OFF
EC8100A	2-pipe	x	x	x	x	x	x
	4-pipe	x	x	x	x	x	x

Operation mode:

- Cooling only applications: Cool, Dry and Fan are available
- Heating mode applications: Auto, Cool, Dry, Fan and Heat are available
- Automode is only available for 4-pipe applications

Temperature Setting: To set the desired room temperature

Fan speed: high, medium, low or automatic

Timer setting: to turn ON/OFF the air conditioner at the desired time

6 Capacity tables

6 - 1 Capacity tables with glycol for process cooling applications

FWB-J (Glycol Correction Factors)

Glycol percentage in weight (%)	Freezing temperature (°C)	Capacity correction factor		Pressure drop correction factor	
		Cooling	Heating	Cooling	Heating
0	0	1	1	1	1
10	-4	0.93	0.98	1.09	1.08
20	-10	0.84	0.97	1.18	1.11
30	-16	0.76	0.94	1.27	1.22
40	-24	0.76	0.91	1.36	1.33

NOTE

1 Correction factors are based on an average value (at rated water flow rate). This can cause deviation depending on conditions used.

1
6

7 Dimensional drawing & centre of gravity

7 - 1 Dimensional drawing

FWB-J

MODEL FWB		02JT	03JT	04/05 JT	06JT	07JT	09JT	10/11 JT
		02JF	03JF	04JF	06JF	07JF	08JF	10JF
A	mm	467	637	767	967	1217	1317	1577
B	mm	505	675	805	1005	1255	1355	1615
C	mm	535	705	835	1035	1285	1385	1645

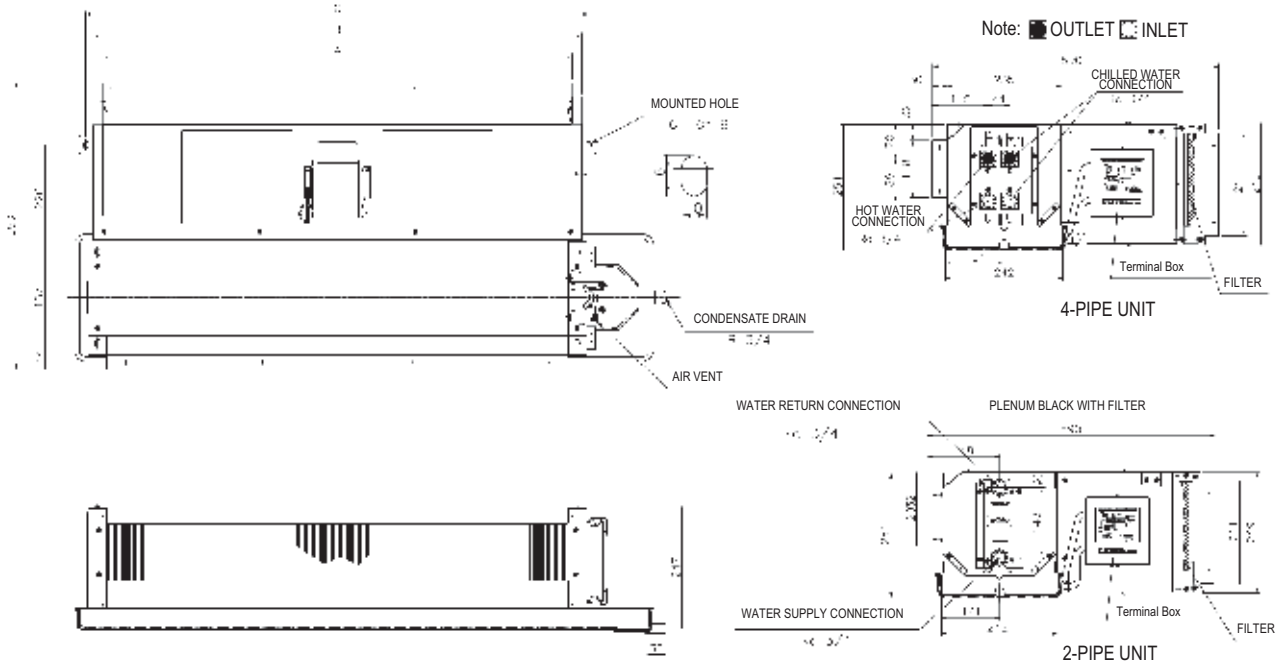

1
7

8 Wiring diagram

8 - 1 Wiring diagram

1
8

FWB02-06J

MODELS	FWB 02J~06J T/F
	2 PIPES & 4 PIPES

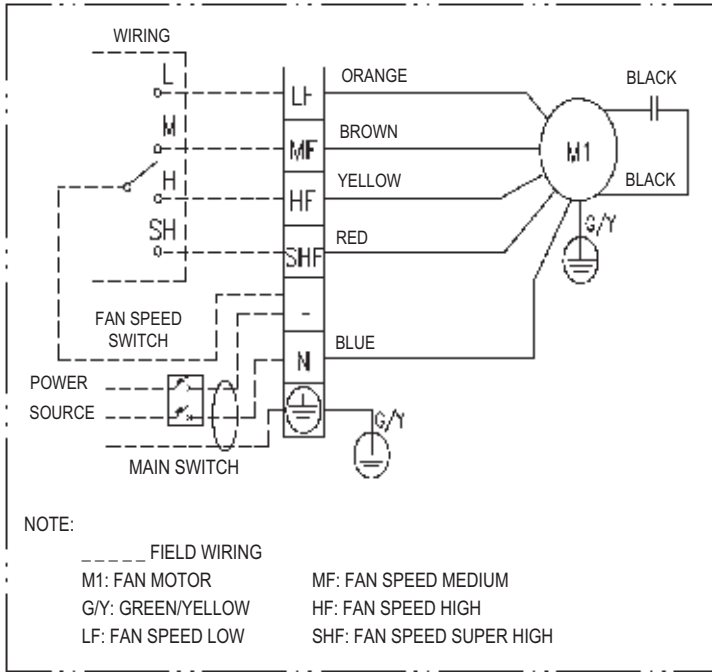

FWB07-11J

MODELS	FWB 07J~11J T/F
	2 PIPES & 4 PIPES

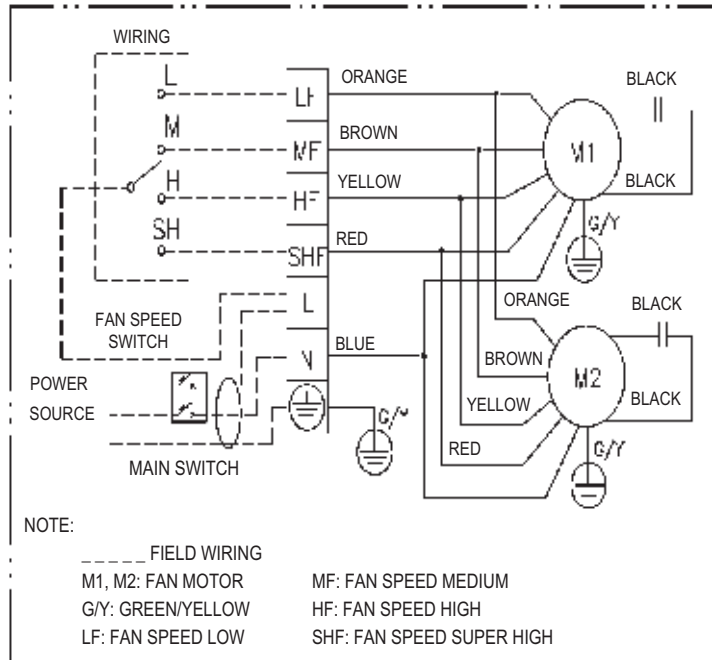

9 Sound data

9 - 1 Sound pressure spectrum

FWB-JT (2 Pipes) Sound Pressure Level [Lp]

Models FWB	Fan Speed	Octave Band Frequency[dB(A)]								Total [dB(A)]
		63Hz	125Hz	250Hz	500Hz	1kHz	2kHz	4kHz	8kHz	
02JT	S.High	40.3	39.6	38.6	38.1	31.8	27.6	20.4	20.2	38.0
	High	39.9	36.9	36.3	36.0	28.6	22.4	17.4	15.2	35.5
	Medium	36.6	30.6	31.6	33.2	25.0	16.6	14.9	14.1	32.0
	Low	35.4	30.1	31.0	32.2	23.4	14.7	12.7	11.3	31.0
03JT	S.High	39.1	40.1	41.6	42.3	36.3	29.0	20.0	15.2	42.0
	High	38.0	39.4	39.6	40.8	34.0	27.1	19.2	14.8	40.0
	Medium	35.1	38.6	37.7	36.5	32.8	22.5	15.8	13.5	37.0
	Low	34.8	34.8	34.0	33.6	32.1	19.8	13.7	11.4	35.0
04JT	S.High	39.9	40.0	39.9	39.9	34.0	35.0	23.5	19.7	41.0
	High	36.1	36.8	35.9	35.1	31.5	30.8	19.3	17.0	37.0
	Medium	32.0	33.1	32.6	31.9	27.6	25.0	16.0	14.2	33.0
	Low	31.3	32.0	31.4	31.0	26.3	23.9	14.3	13.1	32.0
05JT	S.High	39.9	40.0	39.9	39.9	34.0	35.0	23.5	19.7	41.0
	High	37.1	37.8	36.9	38.1	32.5	31.8	20.3	18.0	38.0
	Medium	32.6	33.7	32.9	32.8	28.2	25.6	16.6	14.8	34.0
	Low	32.1	32.8	31.9	31.3	27.1	24.7	15.1	13.9	32.5
06JT	S.High	46.6	43.2	41.4	41.7	39.4	30.9	23.3	20.2	43.0
	High	42.4	42.3	40.5	39.4	35.0	27.3	19.1	18.5	40.0
	Medium	40.3	40.9	39.0	37.3	33.3	25.6	16.3	15.2	38.0
	Low	39.7	38.5	36.9	35.9	28.4	23.2	14.4	13.9	35.5
07JT	S.High	45.1	44.6	42.6	42.5	36.5	34.4	26.0	24.8	43.0
	High	44.8	41.0	41.4	40.1	31.8	29.7	21.4	20.8	40.0
	Medium	41.0	38.7	39.6	37.7	30.0	28.1	20.7	20.2	38.0
	Low	40.3	37.3	36.6	36.6	28.0	22.5	18.2	18.0	36.0
08JT	S.High	45.4	44.9	42.9	42.8	37.0	34.7	26.3	25.1	43.5
	High	44.4	40.6	41.0	39.7	31.2	29.3	21.0	20.4	39.5
	Medium	41.0	38.7	39.6	37.7	30.0	28.1	20.7	20.2	38.0
	Low	40.3	37.3	36.6	36.6	28.0	22.5	18.2	18.0	36.0
09JT	S.High	45.0	43.7	45.1	45.8	38.0	36.3	28.5	25.5	45.5
	High	44.0	41.0	42.3	42.9	35.4	33.4	25.2	23.8	43.0
	Medium	40.1	38.0	39.8	41.1	33.6	31.2	22.3	19.9	41.0
	Low	43.8	40.2	37.3	39.1	32.1	28.6	20.5	18.4	39.0
10JT	S.High	46.3	48.6	46.9	45.0	39.9	37.2	28.1	27.4	46.0
	High	43.5	45.0	45.2	41.2	36.6	35.8	26.3	25.0	43.5
	Medium	41.4	44.4	42.7	38.5	32.1	28.9	20.1	19.7	41.0
	Low	41.0	44.2	40.7	38.3	30.2	28.9	20.6	20.2	39.0
11JT	S.High	46.3	48.6	46.9	45.0	41.3	37.2	28.1	27.4	46.5
	High	43.5	45.0	45.6	41.6	37.1	35.9	26.3	25.0	44.0
	Medium	43.0	46.0	44.3	40.1	33.7	30.5	21.7	21.3	41.5
	Low	41.7	44.9	41.4	39.0	30.9	29.6	21.3	20.9	39.5

Power Supply: 240V/1Ph/50Hz

FWB-JF (4 Pipes) Sound Pressure Level [Lp]

Models FWB	Fan Speed	Octave Band Frequency[dB(A)]								Total [dB(A)]
		63Hz	125Hz	250Hz	500Hz	1kHz	2kHz	4kHz	8kHz	
02JF	S.High	40.3	39.6	38.5	38.1	31.8	27.6	20.4	20.2	38.0
	High	39.6	36.6	35.9	35.6	28.3	22.1	17.1	14.9	35.0
	Medium	37.5	31.5	32.7	34.1	25.9	17.5	15.8	15.0	33.0
	Low	35.5	30.2	31.0	32.3	23.5	14.8	12.8	11.4	31.0
03JF	S.High	39.1	40.1	41.9	42.3	36.3	29.0	20.0	15.2	42.0
	High	38.0	39.4	39.5	41.0	34.0	27.1	19.2	14.8	40.0
	Medium	35.1	38.6	37.5	36.7	32.8	22.5	15.8	13.5	37.0
	Low	34.8	34.8	34.0	33.6	32.1	19.8	13.7	11.4	35.0
04JF	S.High	39.9	40.0	39.9	39.9	34.0	35.0	23.5	19.7	41.0
	High	37.1	37.8	36.9	38.1	32.5	31.8	20.3	18.0	38.0
	Medium	32.6	33.7	32.9	32.8	28.2	25.6	16.6	14.8	34.0
	Low	32.1	32.8	31.9	31.3	27.1	24.7	15.1	13.9	32.5
06JF	S.High	46.6	43.2	42.4	41.7	39.4	30.9	23.3	20.2	43.0
	High	42.4	42.3	40.5	39.4	35.3	27.3	19.1	18.5	40.0
	Medium	40.3	40.9	39.0	37.3	33.3	25.6	16.3	15.2	38.0
	Low	39.7	38.5	36.9	35.9	28.4	23.2	14.4	13.9	35.5
07JF	S.High	45.4	44.9	42.9	42.8	37.0	34.7	26.3	25.1	43.5
	High	44.4	40.6	41.0	39.7	31.2	29.3	21.0	20.4	39.5
	Medium	41.0	38.7	39.6	37.7	30.0	28.1	20.7	20.2	38.0
	Low	40.3	37.3	36.6	36.6	28.0	22.5	18.2	18.0	36.0
08JF	S.High	45.0	43.7	45.1	45.8	38.0	36.3	28.5	25.5	45.5
	High	44.0	41.0	42.3	42.9	35.4	33.4	25.2	23.8	43.0
	Medium	40.1	38.0	39.8	41.1	33.6	31.2	22.3	19.9	41.0
	Low	43.8	40.2	37.3	39.1	32.1	28.6	20.5	18.4	39.0
10JF	S.High	46.3	48.6	46.9	45.0	41.3	37.2	28.1	27.4	46.5
	High	43.5	45.0	45.6	41.6	37.1	35.9	26.3	25.0	44.0
	Medium	43.0	46.0	44.3	40.1	33.7	30.5	21.7	21.3	41.5
	Low	41.7	44.9	41.4	39.0	30.9	29.6	21.3	20.9	39.5

Power Supply: 240V/1Ph/50Hz

9 Sound data

9 - 2 Sound power spectrum

1
9

FWB-JT (2 Pipes) Sound Power Level [Lw]

Models FWB	Fan Speed	Octave Band Frequency[dB(A)]								Total [dB(A)]
		63Hz	125Hz	250Hz	500Hz	1kHz	2kHz	4kHz	8kHz	
02JT	S.High	48.6	51.3	50.9	50.6	42.9	44.9	38.8	32.9	51.5
	High	48.2	45.3	46.6	47.4	40.0	38.7	33.9	23.5	47.5
	Medium	45.0	38.4	41.4	43.6	35.0	30.5	28.9	22.6	43.0
	Low	41.5	37.4	38.4	41.5	34.9	26.9	23.9	20.6	41.0
03JT	S.High	47.4	51.8	54.8	54.6	47.4	46.3	38.4	27.9	55.0
	High	46.3	47.8	49.2	52.1	45.4	43.4	35.7	23.1	52.0
	Medium	42.5	45.4	45.8	47.0	42.6	36.2	29.6	22.0	48.0
	Low	40.7	42.0	42.9	42.6	43.1	31.9	24.9	20.7	45.5
04JT	S.High	47.2	50.7	51.6	51.2	45.1	50.3	41.9	32.4	54.5
	High	44.4	44.7	45.1	45.9	42.7	44.5	35.8	25.3	49.0
	Medium	38.8	39.3	39.9	41.5	37.4	38.1	29.6	22.7	43.5
	Low	37.4	39.3	37.6	40.6	37.0	36.1	25.5	22.4	42.5
05JT	S.High	47.2	50.7	51.6	51.2	45.1	50.3	41.9	32.4	54.5
	High	45.2	45.5	45.9	46.7	43.5	45.3	36.6	26.1	50.0
	Medium	39.3	39.3	39.9	41.5	37.8	38.1	29.6	23.3	44.5
	Low	37.9	39.8	38.1	41.1	37.5	36.6	26.0	22.9	43.0
06JT	S.High	54.9	54.9	56.1	54.0	50.5	48.2	41.7	32.9	56.0
	High	50.7	50.7	52.1	50.5	46.4	43.6	35.6	26.8	52.0
	Medium	47.7	47.7	48.5	47.6	42.9	39.3	30.1	23.7	48.5
	Low	45.8	45.8	46.2	45.3	39.9	35.4	25.6	23.2	46.0
07JT	S.High	56.3	57.1	55.5	52.8	51.6	48.9	41.3	33.4	56.0
	High	53.9	53.1	53.1	49.9	46.9	43.1	34.8	25.5	52.0
	Medium	51.2	51.0	50.6	46.3	42.9	39.7	31.9	24.8	48.5
	Low	50.9	49.1	46.5	45.0	40.7	33.8	28.0	22.6	46.0
08JT	S.High	56.6	57.4	55.8	53.1	51.8	49.2	41.6	33.7	56.5
	High	53.5	52.7	52.7	49.5	46.3	42.7	34.4	25.1	51.5
	Medium	51.2	51.0	50.6	46.1	42.7	39.7	31.9	24.8	48.5
	Low	43.8	44.1	46.2	44.6	40.2	33.6	27.5	22.4	46.0
09JT	S.High	56.2	56.2	58.0	56.1	54.0	50.8	43.8	34.1	58.5
	High	53.1	53.1	54.0	52.7	50.5	46.8	38.6	28.5	55.0
	Medium	50.3	50.3	50.8	49.7	47.1	42.8	33.5	24.5	51.5
	Low	47.3	47.0	47.9	47.1	44.3	39.7	29.8	22.8	49.0
10JT	S.High	57.5	61.1	59.8	55.3	55.3	51.7	43.4	36.0	59.5
	High	52.6	57.1	56.7	51.0	50.5	49.2	39.7	29.7	55.5
	Medium	51.6	56.7	53.7	48.1	46.5	40.8	31.3	24.3	51.5
	Low	51.6	56.0	51.6	46.7	42.9	40.2	30.4	24.8	49.5
11JT	S.High	57.9	61.5	60.2	55.7	55.7	52.1	43.8	36.4	60.0
	High	52.6	57.1	56.7	51.4	50.5	49.3	39.7	29.7	56.0
	Medium	53.2	58.3	55.3	48.1	46.5	40.8	32.9	25.9	52.0
	Low	45.7	52.2	52.5	47.5	43.6	41.2	31.1	25.8	50.0

Power Supply: 240V/1Ph/50Hz

FWB-JF (4 Pipes) Sound Power Level [Lw]

Models FWB	Fan Speed	Octave Band Frequency[dB(A)]								Total [dB(A)]
		63Hz	125Hz	250Hz	500Hz	1kHz	2kHz	4kHz	8kHz	
02JF	S.High	48.6	51.3	50.9	50.6	42.9	44.9	38.8	32.9	51.5
	High	47.8	44.9	45.6	47.0	39.6	38.3	33.5	23.1	47.0
	Medium	46.1	39.5	42.5	44.7	36.1	31.6	30.0	23.7	44.0
	Low	41.6	37.5	38.5	41.6	35.5	27.0	24.0	20.7	41.0
03JF	S.High	47.4	51.8	54.8	54.6	47.4	46.3	38.4	27.9	55.0
	High	46.3	47.8	49.2	52.1	45.1	43.4	35.7	23.1	52.0
	Medium	42.5	45.4	45.8	47.0	42.4	36.2	29.6	22.0	48.0
	Low	40.7	42.0	42.9	42.6	43.1	31.9	24.9	20.7	45.5
04JF	S.High	47.2	50.7	51.6	51.2	45.1	50.3	41.9	32.4	54.5
	High	45.2	45.5	45.9	46.7	43.5	45.3	36.6	26.1	50.0
	Medium	39.3	39.3	39.9	41.5	37.8	38.1	29.6	23.3	44.5
	Low	37.9	39.8	38.1	41.1	37.5	36.6	26.0	22.9	43.0
06JF	S.High	54.9	54.9	56.1	54.0	50.5	48.2	41.7	32.9	56.0
	High	50.7	50.7	52.1	50.5	46.4	43.6	35.6	26.8	52.0
	Medium	47.7	47.7	48.5	47.6	42.9	39.3	30.1	23.7	48.5
	Low	45.8	45.8	46.2	45.3	40.4	35.4	25.6	23.2	46.0
07JF	S.High	56.6	57.4	55.8	53.1	51.8	49.2	41.6	33.7	56.5
	High	53.5	52.7	52.7	49.5	46.3	42.7	34.4	25.1	51.5
	Medium	51.2	51.0	50.6	46.1	42.7	39.7	31.9	24.8	48.5
	Low	43.8	44.1	46.2	44.6	40.2	33.6	27.5	22.4	46.0
08JF	S.High	56.2	56.2	58.0	56.1	54.0	50.8	43.8	34.1	58.5
	High	53.1	53.1	54.0	52.7	50.5	46.8	38.6	28.5	55.0
	Medium	50.3	50.3	50.8	49.7	47.1	42.8	33.5	24.5	51.5
	Low	47.3	47.0	47.9	47.1	44.3	39.7	29.8	22.8	49.0
10JF	S.High	57.9	61.5	60.2	55.7	55.7	52.1	43.8	36.4	60.0
	High	52.6	57.1	56.7	51.4	50.5	49.3	39.7	29.7	56.0
	Medium	53.2	58.3	55.3	48.1	46.5	40.8	32.9	25.9	52.0
	Low	45.7	52.2	52.5	47.5	43.6	41.2	31.1	25.8	50.0

Power Supply: 240V/1Ph/50Hz

10 Operation range

FWB-J

OPERATING LIMITS	
Maximum water-side pressure	16 bar
Minimum entering water temperature	3°C
Maximum entering water temperature	95°C
Minimum air inlet temperature	5°C
Maximum air inlet temperature	43°C
Power supply	220-240V/ 1Ph / 50Hz

1

10

11 Hydraulic performance

11 - 1 Water pressure drop curve evaporator

FWB-JT

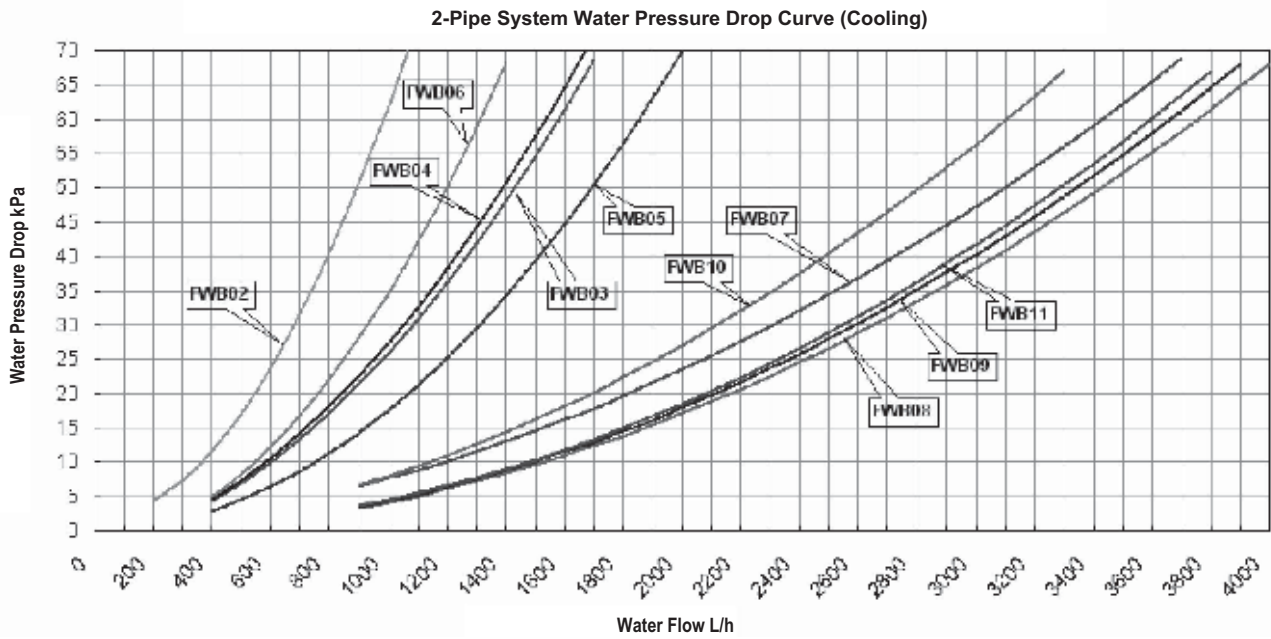

NOTE

The pressure drop is only for the coil and excludes water connections and valves.

FWB-JT

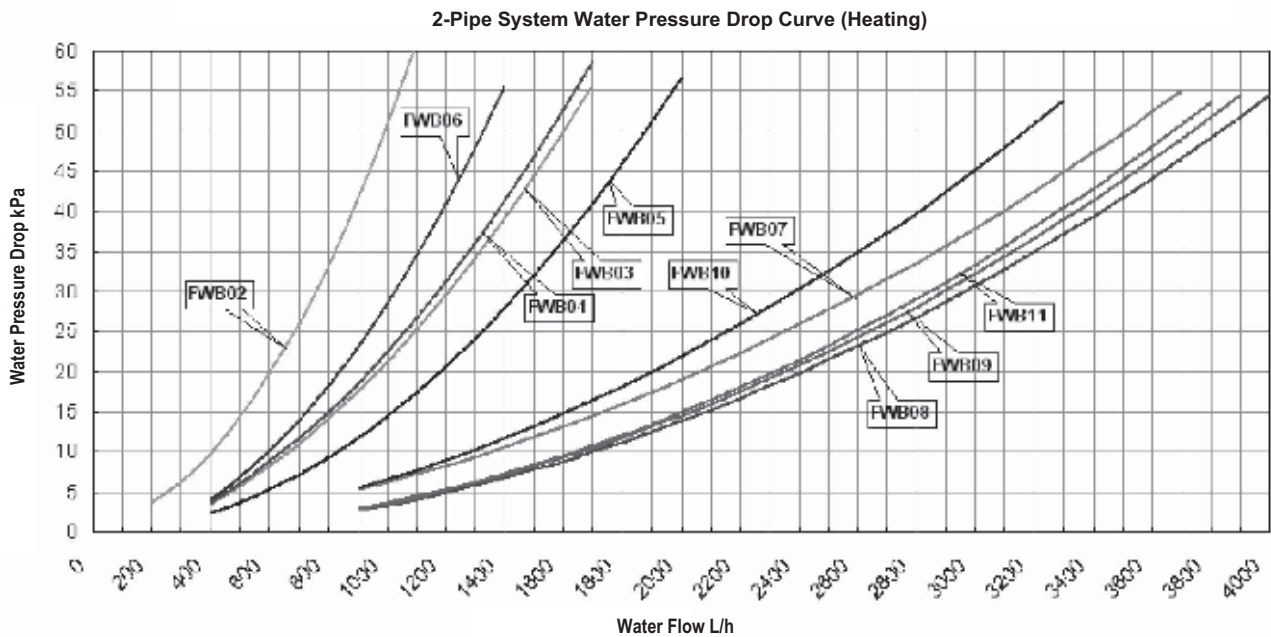

NOTE

The pressure drop is only for the coil and excludes water connections and valves.

11 Hydraulic performance

11 - 1 Water pressure drop curve evaporator

FWB-JF

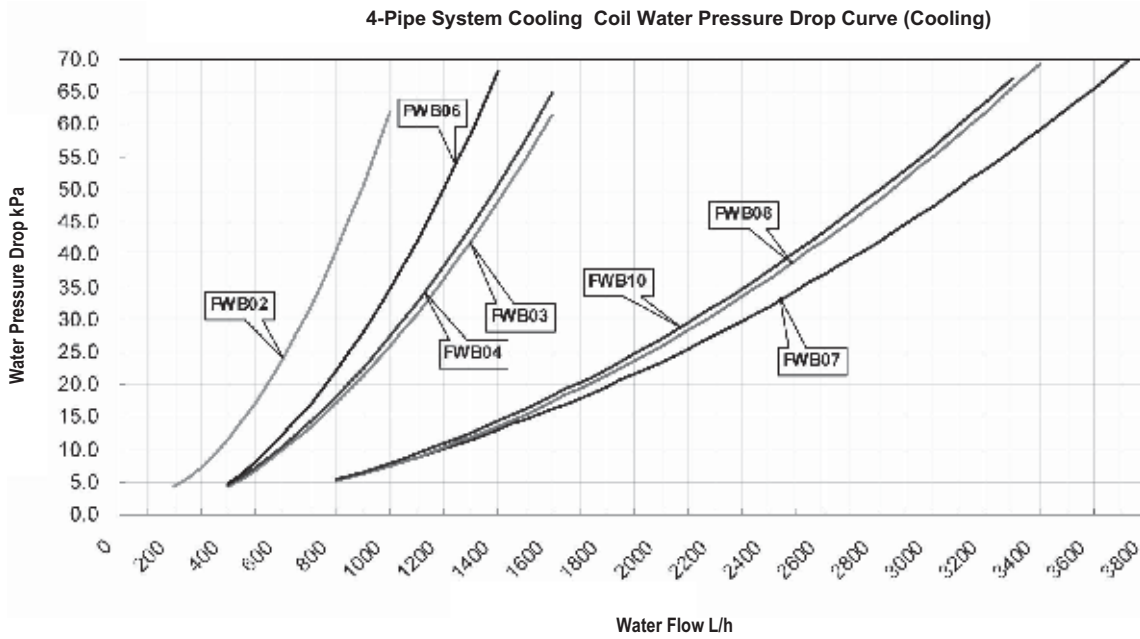

NOTE

The pressure drop is only for the coil and excludes water connections and valves.

FWB-JF

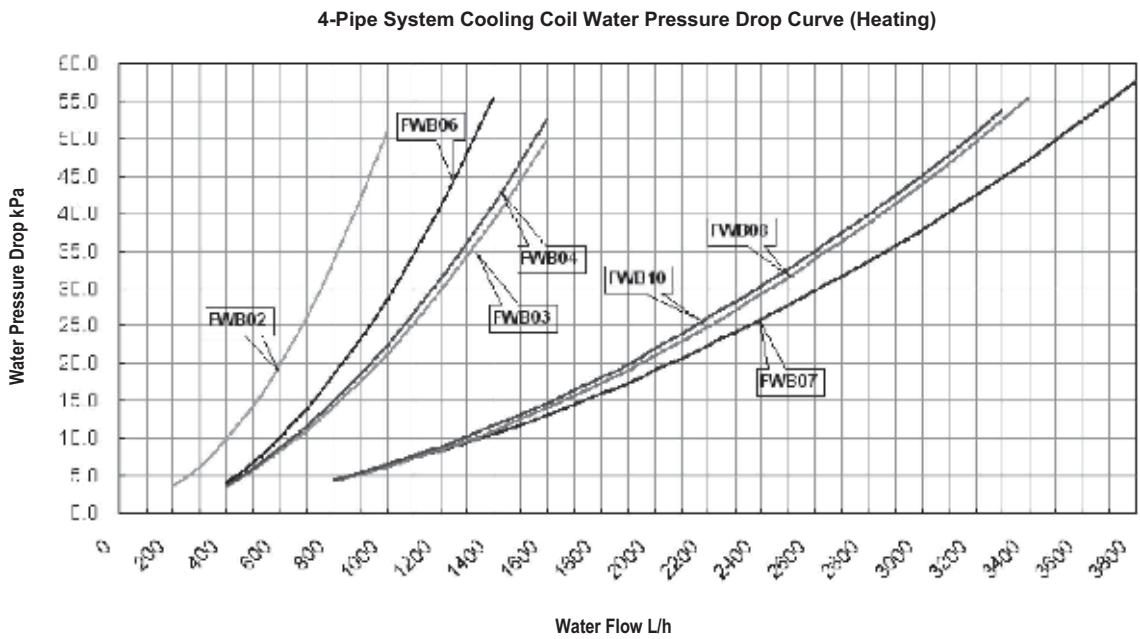

NOTE

The pressure drop is only for the coil and excludes water connections and valves.

11 Hydraulic performance

11 - 1 Water pressure drop curve evaporator

FWB-JF

4-Pipe System Heating Coil Water Pressure Drop Curve (Heating)

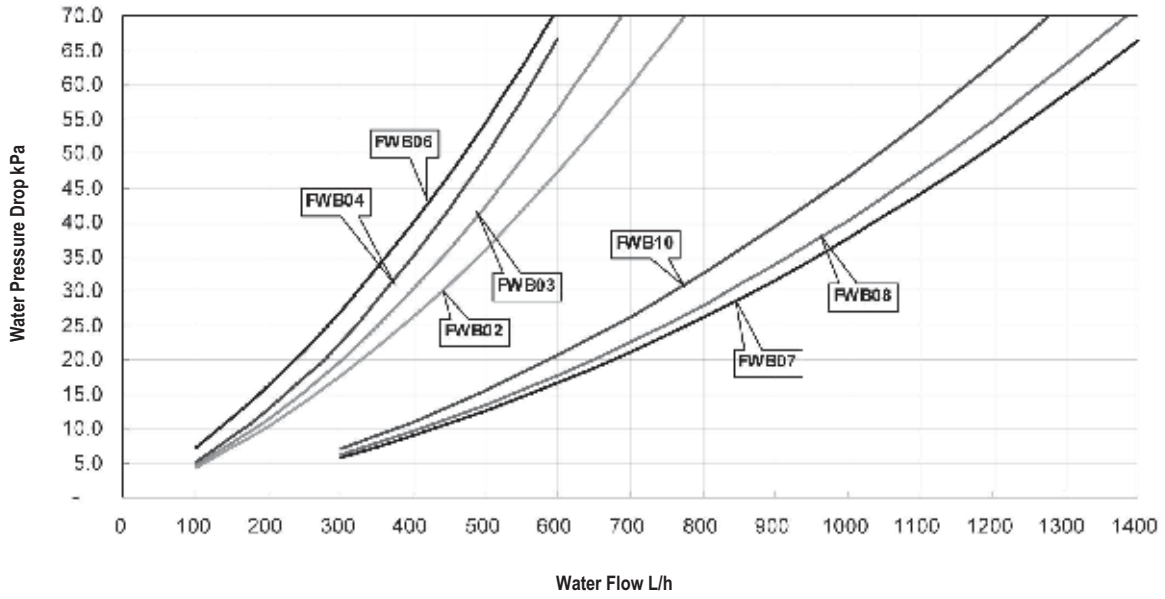

NOTE

The pressure drop is only for the coil and excludes water connections and valves.