

## Стандартные насосы

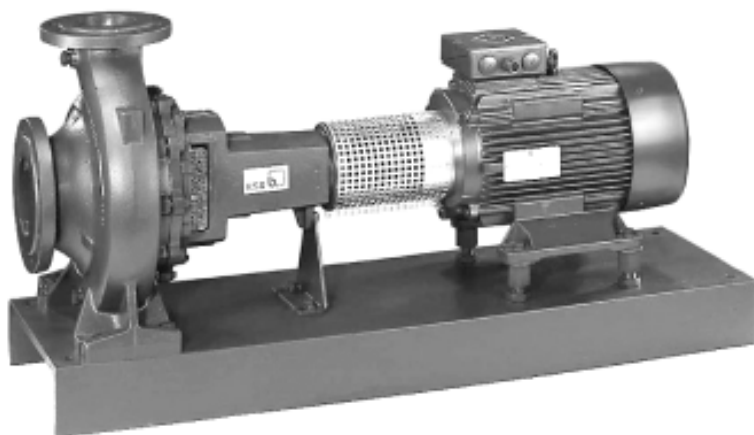

### Автоматизация возможна с шкафами управления:

- PumpExpert
- Hyа-Drive
- Hyаmaster
- hyatronic

### Области применения

- Общее водоснабжение
- Установки пожаротушения
- Дождевание
- Орошение
- Осушение
- Отопление
- Кондиционирование
- Питьевая вода
- Техническая вода
- Горячая вода
- Охлаждающая вода
- Вода плавательных бассейнов
- Морская вода
- Вода для пожаротушения
- Солонатовая вода
- Конденсат
- Солевые растворы
- Нефть
- Чистящие средства

### Перекачиваемая среда

Очищенные жидкости, не оказывающие химического и механического воздействия на конструкционные материалы насоса.

### Эксплуатационные характеристики

Q до 1900 м<sup>3</sup>/час, (528 л/с)  
H до 102 м  
t от -30°C до +140°C  
p<sub>d</sub> до 16 бар <sup>1)</sup>

<sup>1)</sup> см. границы диапазона по давлению/температуре на стр. 5

### Конструкция / Исполнение

Горизонтальные насосы со спиральным корпусом, одноступенчатые (типоразмеры 125-500/2 - двухступенчатые), с производительностью и присоединительными размерами согласно EN 733 до типоразмера DN 200 / расширенной версии Etanorm-R, с подшипниковым узлом, в процессном исполнении.

Вал в зоне уплотнения вала со сменной втулкой вала / защитной втулкой вала.

Спиральный корпус и рабочее колесо со сменным щелевым кольцом.

Спиральный корпус с литой опорной лапой насоса.

### Подшипник

Радиальный шарикоподшипник, смазываемый консистентной смазкой.

### Уплотнение вала

Торцовое уплотнение по EN 12756 (стандартное для Etanorm и как опция для Etanorm-R) или сальниковое уплотнение.

### Обозначение

Типоряд Etanorm \_\_\_\_\_ EN(-R) 40-160 [43(6238) G 10] <sup>\*</sup>)  
Типоразмер, напри. \_\_\_\_\_  
Рабочее колесо: Ø-100 мм, напри., 143 мм = \_\_\_\_\_ (наклонно обточенное рабочее колесо) напри., Ø 162/138 мм = \_\_\_\_\_  
Материал исполнения корпуса, напри. JL 1040 <sup>2)</sup> \_\_\_\_\_  
Уплотнение вала, напри., торцовое уплотнение Q1 Q1 X4GG \_\_\_\_\_

<sup>2)</sup> по EN 1561 = GJL-250

<sup>\*</sup>) действительно только для Etanorm

### Принадлежности

#### Привод

Поверхностноохлаждаемый IEC-трехфазный двигатель с короткозамкнутым ротором.

Обмотка: до 2,2 кВт 220-240 В/380-420 В  
от 3 кВт 380-420 В / 660-725 В

Конструкция: IMB 3

Степень защиты: IP 55

Класс изоляции: F с температурным датчиком: 3 термистора

Режим эксплуатации: непрерывный режим работы S1

#### Муфта

Эластичная муфта с / без проставком.

#### Защитное ограждение

Защитное ограждение муфты по EN 294.

#### Опорная плита

Профилированная сталь / стальной лист необходимого размера для насосного агрегата в сборе (насос и двигатель) в стойком против скручивания исполнении.



General Member of



**Etanorm**

n = 2900 об/мин

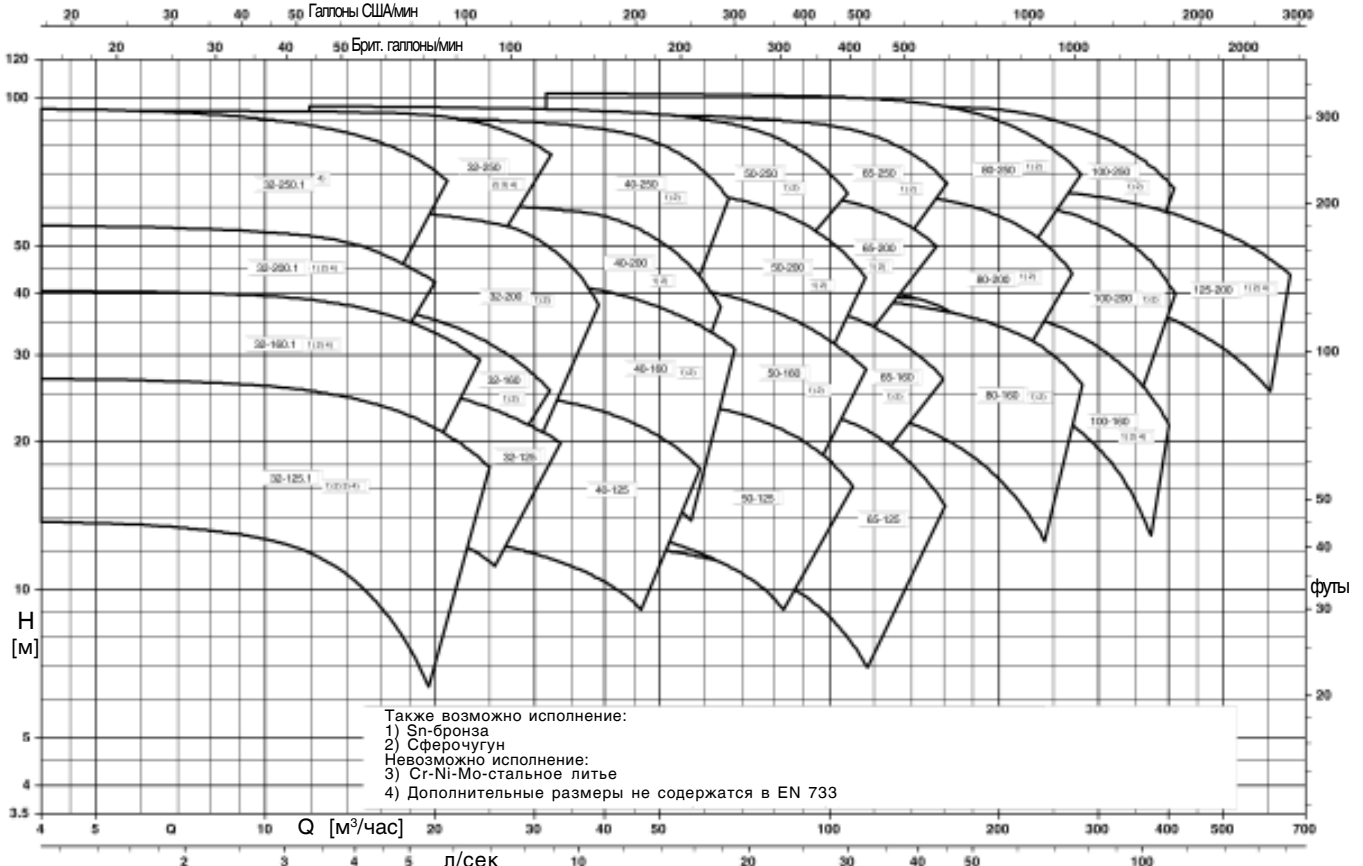

**Etanorm / Etabloc / Etanorm-R**

n = 1450 об/мин

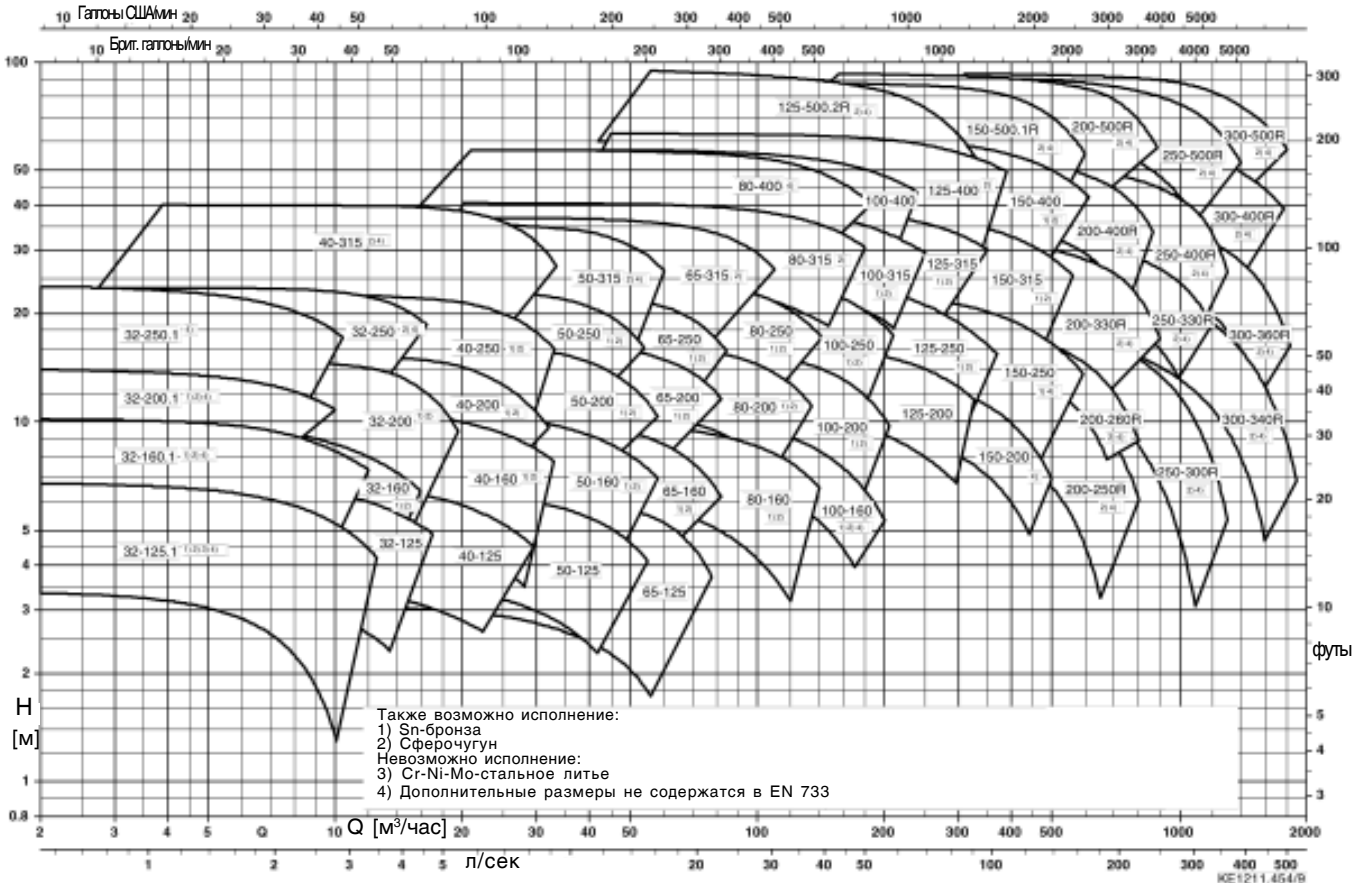

**Etanorm**

n = 3500 об/мин

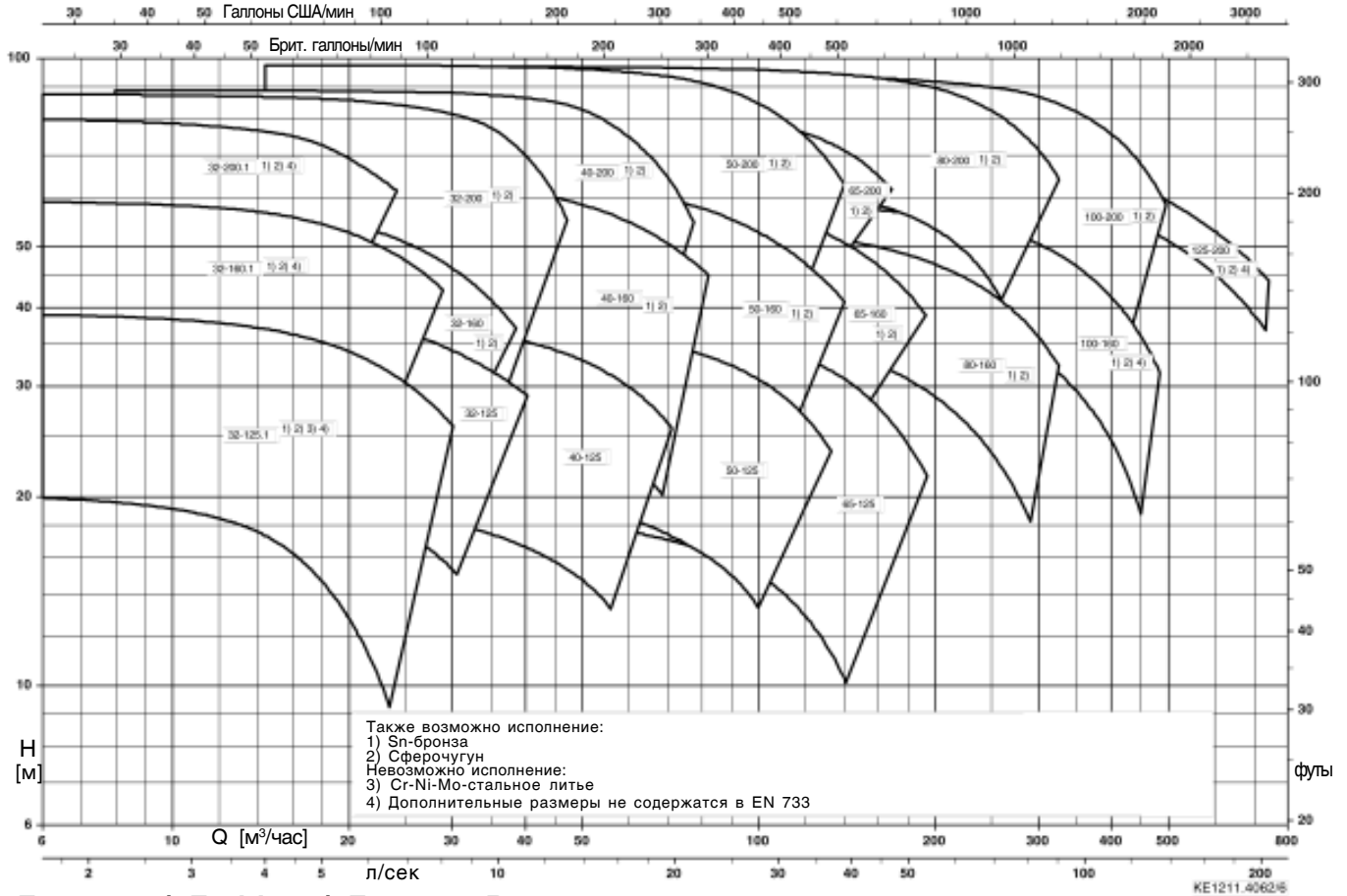

**Etanorm / Etabloc / Etanorm-R**

n = 1750 об/мин

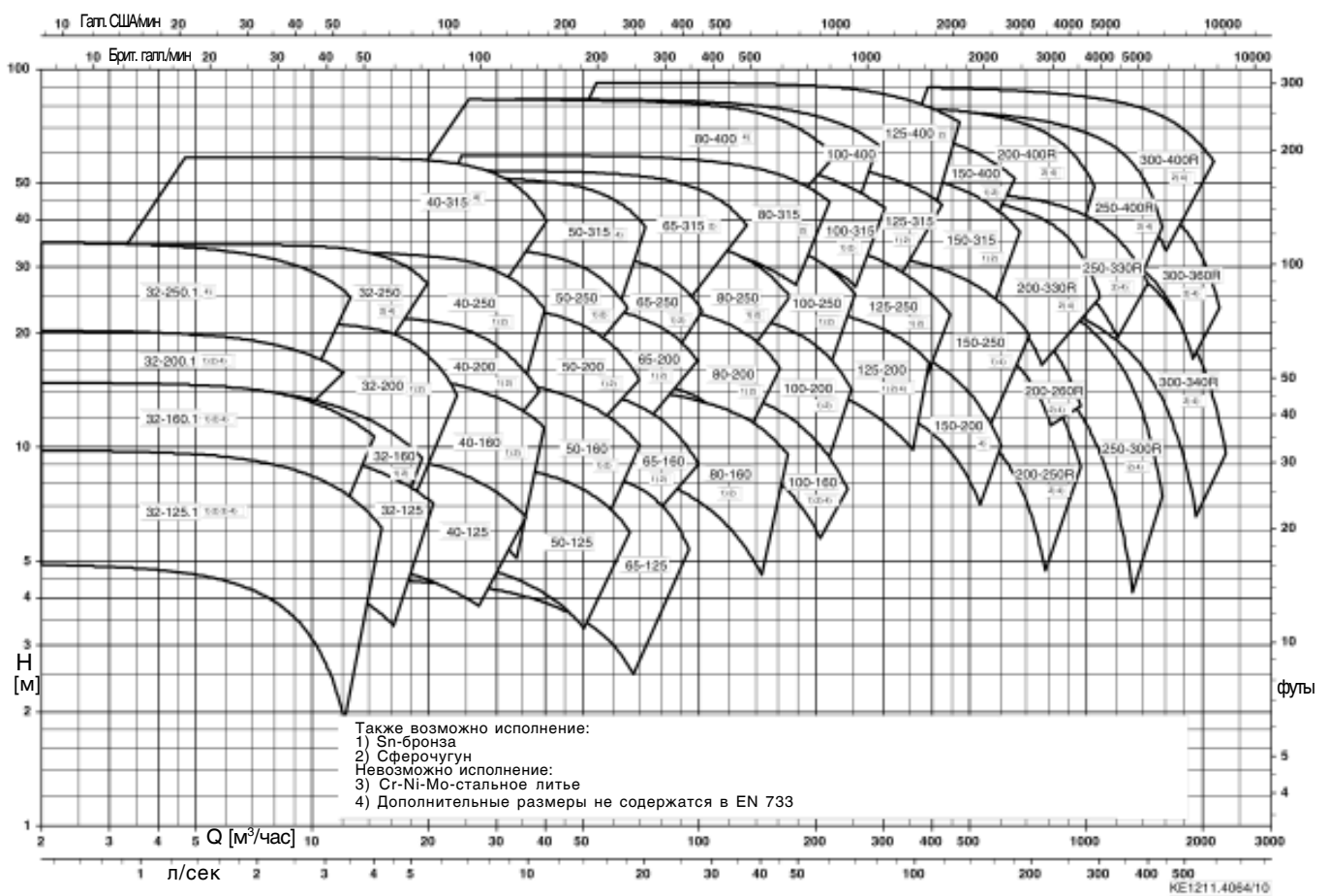

## Материал

	Etanorm G / Etanorm-RG	Etanorm-R GC1	Etanorm M	Etanorm-RM	Etanorm B
Спиральный корпус	Серый чугун JL 1040 <sup>1)</sup>		Серый чугун JL 1040 <sup>1)</sup>		Sn-бронза CC 480 K-GS <sup>3)</sup>
Крышка корпуса	Серый чугун JL 1040 <sup>1)</sup>		Серый чугун JL 1040 <sup>1)</sup>		Sn-бронза CC 480 K-GS <sup>3)</sup>
Рабочее колесо	Серый чугун JL 1040 <sup>1)</sup>	1.4408	Sn-бронза CC 480 K-GS <sup>3)</sup>		Sn-бронза CC 480 K-GS <sup>3)</sup>
Щелевое кольцо	Серый чугун GG	1.4408	Серый чугун / Pb-бронза GG / G-CuPb10Sn		Pb-бронза CC 495 K-GS <sup>3)</sup>
Вал	Улучшенная сталь C45		Улучшенная сталь C45		Cr-Ni-Mo-сталь 1.4462
Втулка вала	Cr-Ni-Mo-сталь 1.4571	1.4122	Cr-Ni-Mo-сталь 1.4571	1.4122	Cr-Ni-Mo-сталь 1.4571
Защитная втулка вала	Cr-Mo-сталь 1.4122		Cr-Mo-сталь 1.4122		Cr-Ni-Mo-сталь 1.4571
Корпус подшипника	Серый чугун JL 1040 <sup>1)</sup>		Серый чугун JL 1040 <sup>1)</sup>		Серый чугун JL 1040 <sup>1)</sup>

	Etanorm S	Etanorm-RS	Etanorm C
Спиральный корпус	Сферочугун JS1025 <sup>2)</sup>		Cr-Ni-Mo-стальное литье 1.4408
Крышка корпуса	Сферочугун JS1025 <sup>2)</sup>		Cr-Ni-Mo-стальное литье 1.4408
Рабочее колесо	Серый чугун JL 1040 <sup>1)</sup>		Cr-Ni-Mo-стальное литье 1.4408
Щелевое кольцо	Серый чугун GG		Cr-Ni-Mo-стальное литье 1.4408
Вал	Улучшенная сталь C45		Cr-Ni-Mo-сталь 1.4462
Втулка вала	Cr-Ni-Mo-сталь 1.4571	1.4122	Cr-Ni-Mo-сталь 1.4571
Защитная втулка вала	Cr-Mo-сталь 1.4122		Cr-Ni-Mo-сталь 1.4571
Корпус подшипника	Серый чугун JL 1040 <sup>1)</sup>		Серый чугун JL 1040 <sup>1)</sup>

- 1) по EN 1561 = GJL-250  
 2) по EN 1563 = GLS-400-18-LT  
 3) по EN 1982

## Очевидные преимущества конструкции

**Выбор материала исполнения в зависимости от типоразмера**  
 Серый чугун, Sn-бронза, Сферочугун, Cr-Ni-Mo-стальное литье

**Корпусные детали рассчитаны на давление до 16 бар для обеспечения высокой эксплуатационной безопасности**

### Исполнение: Etanorm-R

**Присоединительные размеры и производительность** согласно EN 733 (Etanorm)

**Щелевые кольца** удобные в обслуживании

**Геометрия подающего патрубка** обеспечивает высокую всасывающую способность и повышенный кавитационный запас

**Рабочее колесо** с оптимизированной проточной частью, выдающаяся эффективность и узкий шаг QH-характеристик

**Торцовое уплотнение либо сальниковое набивочное уплотнение, неохлаждаемое**

**Процессное конструктивное исполнение, легкий демонтаж,** корпус насоса остается в трубопроводе

**Защитная втулка вала** предотвращает износ вала

**Прочные радиальные шарикоподшипники с лабиринтным кольцом,** защищающим от загрязнений

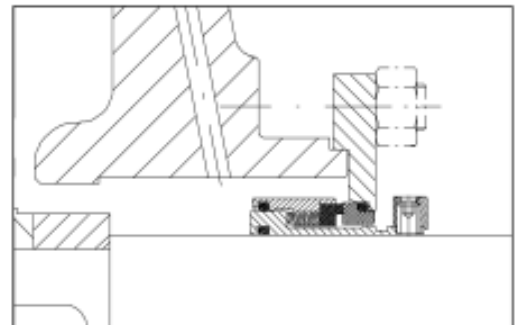

001438

1211; 132/4

## Границы давления и температуры

Etanorm/ Etanorm-R	Температура перекачиваемой жидкости 1) 4)	Конечное давление $p_2$ 2)	Измеренное давление 3)	
			Etanorm	Etanorm-R
G	от -30°C до +140°C	5)	до 21 бар	до 15 бар
M	от -30°C до +140°C		до 21 бар	до 15 бар
S	от -30°C до +140°C		до 25 бар	до 24 бар
B	от -30°C до +140°C	10 бар	до 13 бар	- -
C	от -30°C до +140°C	5)	до 21 бар	- -

- 1) При перекачивании горячей воды в отопительных установках по DIN 4752, раздел 4.5, тщательно соблюдать границы эксплуатации
- 2) Суммарное значение давления на входе и напоре при нулевой подаче не может превышать указанного значения
- 3) Части корпуса проходят испытания на герметичность путем измерения внутреннего давления по AN 1897/75-03 D00 с водой
- 4) Для работы при температуре перекачиваемой жидкости выше 140°C предназначен насос Etanorm SYN
- 5) В соответствии с диаграммой

## Зависимость давление-температура для фланца по EN 1092-1 и EN 1092-2

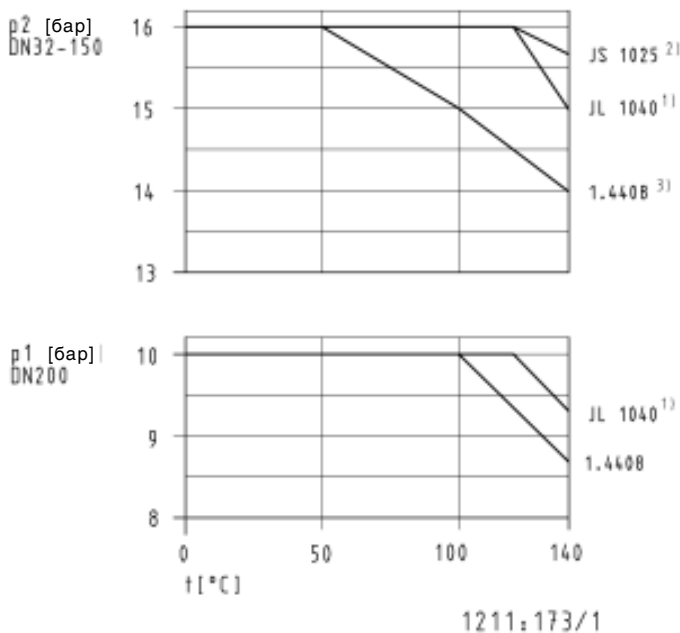

## Etanorm-R

Все типоразмеры

Etanorm-R

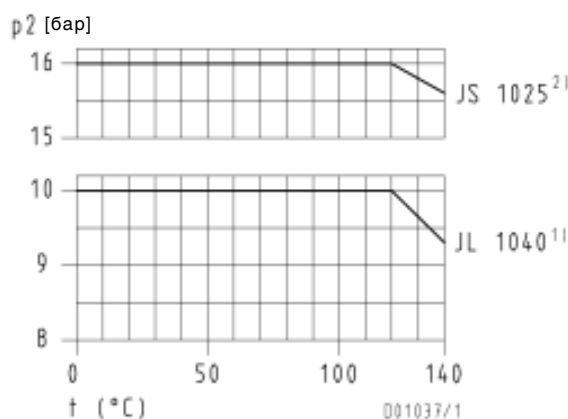

- 1) по EN 1561 = GJL-250
- 2) по EN 1563 = GLS-400-18-LT
- 3) только DN 65-150; DN 32-50 16 бар

## Поставляемые типоразмеры, соответствующие различным материалам

Типоразмер	Etanorm				
	G	M	S	B	C
32-125.1	X	X	X	X	-
32-160.1	X	X	X	X	X
32-200.1	X	X	X	X	X
32-250.1	X	X	-	-	X
32-125	X	X	X	X	X
32-160	X	X	X	X	X
32-200	X	X	X	X	X
32-250	X	X	X	X	X
40-125	X	X	-	-	X
40-160	X	X	X	X	X
40-200	X	X	X	X	X
40-250	X	X	X	X	X
40-315	X	X	X	-	X
50-125	X	X	-	-	X
50-160	X	X	X	X	X
50-200	X	X	X	X	X
50-250	X	X	X	X	X
50-315	X	X	X	-	X
65-125	X	X	-	-	X
65-160	X	X	X	X	X
65-200	X	X	X	X	X
65-250	X	X	X	X	X
65-315	X	X	X	-	X
80-160	X	X	X	X	X
80-200	X	X	X	X	X
80-250	X	X	X	X	X
80-315	X	X	X	X	X
80-400	X	X	-	-	X
100-160	X	X	X	X	X
100-200	X	X	X	X	X
100-250	X	X	X	X	X
100-315	X	X	X	X	X
100-400	X	X	-	-	X
125-200	X	X	X	X	X
125-250	X	X	X	X	X
125-315	X	X	X	X	X
125-400	X	X	X	-	X
150-200	X	X	-	-	X
150-250	X	X	-	X	X
150-315	X	X	X	X	X
150-400	X	X	X	X	X

Типоразмер	Etanorm-R			
	G	GC1	M	S
125-500/2	X	X	X	X
150-500.1	X	X	X	X
200-250	X	X	X	X
200-260	X	X	X	X
200-330	X	X	X	X
200-400	X	X	X	X
200-500	X	X	X	X
250-300	X	X	X	X
250-330	X	X	X	X
250-400	X	X	X	X
250-500	X	X	X	X
300-340	X	X	X	X
300-360	X	X	X	X
300-400	X	X	X	X
300-500	X	X	X	X

## Etanorm

Перекачиваемая жидкость	Границы рабочего диапазона	Материал <sup>9)</sup>					Уплотнение вала						Код исполнения		Примечания	
		Корпус насоса / Корпусное колесо					Сальниковое уплотн.		Торцовое уплотнение				Сальник. уплотн.	Торцовое уплотнение		
		Серый чугун/серый чугун	Серый чугун/ Sn-бронза	Сферочугун/серый чугун	Sn-бронза/ Sn-бронза	Cr-Ni-Mo-сталь/ Cr-Ni-Mo-сталь	RT-P	Чистый графит	US8EGG 4)	USL3X4GG	Q1Q1X4GG	B01EGG				Q101MMGG
G	M	S	B	C	1	3	6	9	10	11	12	Na: p1 ≤ 0,5 бар	Nb: p1 > 0,5 бар			
<b>Вода</b>																
Солоноватая вода 3)	t ≤ 25 °C; p ≤ 10 бар				X		X			X				B1	B10	Cr-Ni-Mo-стальное литье возможно
Конденсат 2)	t ≤ 120 °C; p ≤ 10 бар	X					X							G1	G11	
Конденсат ненормированный	t ≤ 120 °C; p ≤ 10 бар					X	X							C1	C11	
Охлаждающая вода 1) (без антифриза)	t ≤ 60 °C <sup>7)</sup> ; p ≤ 10 бар	X					X			X				G1	G10	При открытой циркуляционной системе предусмотреть: M1/M10
Охлаждающая вода при значениях pH ≥ 7,5 (с антифризом) 5)	t ≤ 120 °C; p ≤ 10 бар	X					X				X			G1	G11	При открытой циркуляционной системе предусмотреть: M1/M10
Вода водохранилищ 1)	t ≤ 40 °C; p ≤ 10 бар				X		X			X				B1	B10	В случае содержания твердых веществ требуется запрос на KSB
Питьевая вода 1)	t ≤ 60 °C <sup>7)</sup> ; p ≤ 10 бар		X				X			X				M1	M10	
Вода для пожаротушения 1)	t ≤ 60 °C <sup>7)</sup> ; p ≤ 10 бар		X				X			X				M1	M10	При поставке по VdS-направлению требуется запрос на KSB
Полностью обессоленная (VE) вода	t ≤ 120 °C; p ≤ 10 бар					X	X				X			C1	C11	Не требуется выполнения норм по чистоте перекачиваемой жидкости
Полностью обессоленная (VE) вода для питания котлов 2)	t ≤ 120 °C; p ≤ 10 бар	X					X				X			G1	G11	
Горячая вода 2)	t ≤ 120 °C; p ≤ 10 бар	X					X				X			G1	G11	При применении в качестве циркуляционного насоса по DIN4752 p <sub>max</sub> ≤ 10 бар. При перекачивании вязких жидкостей - материал "S"
Горячая вода 2)	t ≤ 140 °C; p ≤ 16 бар	X						X	X					G3	G6	
Горячая вода 2)	t ≤ 110 °C; p ≤ 10 бар	X					X			X				G1	G10	
Частично обессоленная вода 2)	t ≤ 60 °C <sup>8)</sup> ; p ≤ 10 бар		X				X				X			M1	M11	
Очищенная вода 6)	t ≤ 60 °C <sup>8)</sup> ; p ≤ 10 бар	X					X				X			G1	G11	
Водопроводная вода 1)	t ≤ 25 °C; p ≤ 10 бар				X		X			X				B1	B10	
Морская вода 3)	t ≤ 60 °C <sup>7)</sup> ; p ≤ 10 бар	X					X			X				G1	G10	Cr-Ni-Mo-стальное литье возможно
Слабозагрязненная вода 1)	t ≤ 30 °C; t ≤ 110 °C	X					X				X			G1	G11	
Вода плавательных бассейнов (пресная вода) 1)	t ≤ 60 °C <sup>7)</sup> ; p ≤ 10 бар	X					X			X				G1	G10	Действительно также при перекачивании по DIN 19 643
Вода плавательных бассейнов (морская вода) 3)	t ≤ 60 °C; p ≤ 10 бар	X					X			X				G1	G10	Cr-Ni-Mo-стальное литье при t ≤ +25°C возможно
<b>Хладагенты, охлаждающие растворы</b>																
Охлаждающие растворы; неорганич. в-ва, значения pH > 7,5; ингибирован.	t > -30 °C; t ≤ 25 °C	X					X				X			G1	G11	
Вода с антифризом при значениях pH ≥ 7,5 1), 5)	t > -30 °C; t ≤ 110 °C	X					X				X			G1	G11	
<b>Масла / эмульсии</b>																
Дизельное масло, мазут EL	t ≤ 60 °C; p ≤ 10 бар			X							X				S10	Материал GG - возможен, при этом не требуется соблюдения каких-либо предписаний
Средство при сверлении/шлифовании	t ≤ 60 °C; p ≤ 10 бар	X									X			G1	G9	
Смазочное масло, турбинное масло, не действительно для SF-D-масел (тяжелых, горючих)	t ≤ 80 °C; p ≤ 10 бар			X							X				S10	При перекачивании жидкости без внутренних норм требуется запрос на KSB. Материал GG - возможен, при этом не требуется соблюдения каких-либо предписаний
Масляно-водная эмульсия	t ≤ 60 °C; p ≤ 10 бар	X									X			G1	G9	
<b>Средства очистки</b>																
Мощный щелок для промывочного спреевого аппарата	t ≤ 90 °C; p ≤ 10 бар	X					X							G1	G7	Q1, Q1, EGG
<b>Применение в пивоварении</b>																
Пивной солод	t ≤ 100 °C; p ≤ 10 бар	X										X			G12	При опасности сухого хода из-за повышенного опорожнения камеры рекомендуется применять двойное торцовое уплотнение в tandemном расположении
Пивное сусло	t ≤ 100 °C; p ≤ 10 бар	X										X			G12	

- Общие критерии оценки при проведении анализа воды: pH ≥ 7; содержание хлоридов (Cl) ≤ 250 мг/кг. Хлор (Cl<sub>2</sub>) ≤ 0,6 мг/кг.
- Водоподготовка по VdTUV 1466; дополнительное условие: содержание O<sub>2</sub> ≤ 0,02 мг/л.
- Для деталей из бронзы действительно: содержание аммиака (NH<sub>3</sub>) ≤ 5 мг/кг, отсутствие сероводорода (H<sub>2</sub>S); при этом возможное ограничение на содержание хлора (Cl) не вводится. В случае несоблюдения предельных значений требуется запрос.
- Действительно только для узла вала 25 и 35, узел вала 55 = AQ1EGG Устройство узла вала см. стр. 15.
- Антифриз на базе этиленгликоля с ингибиторами. Содержание от 20% до 50% (например, антифриз N).
- Не имеется требований по особой чистоте воды! Электропроводность при 25 °C ≤ 800 микроСименс/см, коррозионная среда нейтральная.
- Торцовое уплотнений допустимо для t ≤ 110 °C.
- Торцовое уплотнений допустимо для t ≤ 120 °C.
- Таблицу материалов в зависимости от типоразмера см. на стр. 5.

**Пример выбора:**

 Дано: чистая вода 15 °C; Q=60 м<sup>3</sup>/час; H=80 м

Etanorm G 50-250 G1 (или G11)

**Выбрано:**

Варианты материала (согласно приведенным выше данным в Таблице) \_\_\_\_\_

Типоразмер (согласно характеристике при 2900 об/мин) \_\_\_\_\_

Код исполнения (согласно приведенным выше данным в Таблице) в соотв. с \_\_\_\_\_

требуемой мощностью привода 22 кВт

## Etanorm-R

Перекачиваемая жидкость	Границы рабочего диапазона	Материал			Уплотнение вала		Код исполнения	
		G	M	S	Сальниковое уплотнение	Торцовое уплотнение	Сальниковое уплотнение	Торцовое уплотнение
							Na: $P_1 \leq 0,5$ бар	
							Nb: $P_1 > 0,5$ бар	
<b>Вода</b>								
Конденсат 2)	$t \leq 120$ °C ; $p \leq 10$ бар	X			X		G1	Запрос на KSB
Охлаждающая вода 1) (без антифриза)	$t \leq 60$ °C; $p \leq 10$ бар	X			X	X	G1	G4
Охлаждающая вода при значениях pH $\geq 7,5$ (с антифризом) 5)	$t \geq -30$ °C ; $t \leq 110$ °C ; $p \leq 10$ бар	X			X	X	G1	G4
Вода водохранилищ 1)	$t \leq 60$ °C; $p \leq 10$ бар		X			X	-	M4
Питьевая вода 1)	$t \leq 60$ °C; $p \leq 10$ бар		X		X	X	M1	M4
Вода для пожаротушения 1)	$t \leq 60$ °C; $p \leq 10$ бар		X			X	-	M4
Полностью обессоленная (VE) вода для питания котлов 2)	$t \leq 120$ °C ; $p \leq 10$ бар	X			X	X	G1	G4
Горячая вода 2)	$t \leq 120$ °C; $p \leq 10$ бар	X			X	X	G1	G4
Горячая вода 2)	$t \leq 140$ °C; $p \leq 16$ бар			X	X	X	S1	S4
Горячая вода 2)	$t \leq 110$ °C; $p \leq 10$ бар	X			X	X	G1	G4
Частично обессоленная вода 2)	$t \leq 120$ °C ; $p \leq 10$ бар	X			X		G1	Запрос на KSB
Очищенная вода 4)	$t \leq 25$ °C; $p \leq 10$ бар	X			X	X	G1	G4
Водопроводная вода (промышленное применение) 1)	$t \leq 60$ °C; $p \leq 10$ бар	X			X	X	G1	G4
Водопроводная вода (орошение) 1)	$t \leq 60$ °C; $p \leq 10$ бар	X				X	-	G4
Техническая вода	$t \leq 60$ °C; $p \leq 10$ бар	X				X	-	G4
Слабозагрязненная вода 1)	$t \leq 60$ °C; $p \leq 10$ бар	X			X	X	G1	G4
Вода плавательных бассейнов (пресная вода) 1)	$t \leq 60$ °C; $p \leq 10$ бар	X			X	X	G1	G4
<b>Хладагенты, охлаждающие растворы</b>								
Охлаждающие растворы; неорганические в-ва, значения pH > 7,5; ингибированные	$t \geq -30$ °C; $t \leq 25$ °C ; $p \leq 10$ бар	X			X	X	G1	G4
Вода с антифризом при значениях pH $\geq 7,5$ 1), 3)	$t \geq -30$ °C; $t \leq 110$ °C ; $p \leq 10$ бар	X			X	X	G1	G4
<b>Масла / эмульсии</b>								
Дизельное масло, мазут EL	$t \leq 60$ °C; $p \leq 10$ бар			X		X		S4
Средство при сверлении/шлифовании	$t \leq 60$ °C; $p \leq 10$ бар	X				X		G4
Смазочное масло, турбинное масло, не действительно для SF-D-масел (тяжелых, горючих)	$t \leq 80$ °C; $p \leq 10$ бар			X		X		S4
Масляно-водная эмульсия	$t \leq 60$ °C; $p \leq 10$ бар	X			X	X	G1	G4
<b>Средства очистки</b>								
Моющий щеток для промышленного стравивающего аппарата	$t \leq 90$ °C; $p \leq 10$ бар	X			X		G1	
<b>Применение в пивоварении</b>								
Пивной солод	$t \leq 100$ °C; $p \leq 10$ бар	X			X	X		G4
Пивное сусло	$t \leq 100$ °C; $p \leq 10$ бар	X				X		G4

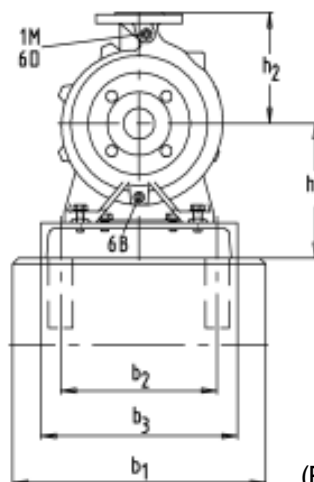
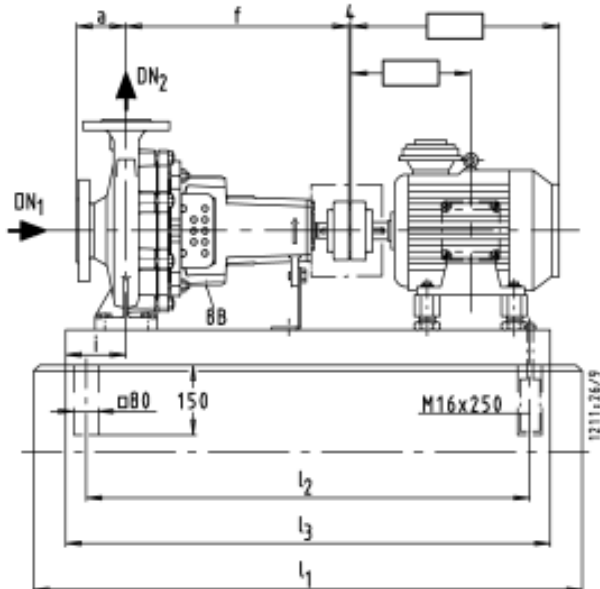

- 1) Общие критерии оценки при проведении анализа воды: pH  $\geq 7$ ; содержание хлоридов (Cl)  $\leq 250$  мг/кг. Хлор (Cl<sub>2</sub>)  $\leq 0,6$  мг/кг.
- 2) Водоподготовка по VdTUV 1466; дополнительное условие: содержание O<sub>2</sub>  $\leq 0,02$  мг/л.
- 3) Антифриз на базе этиленгликоля с ингибиторами. Содержание от 20% до 50% (например, антифриз N).
- 4) Не имеется требований по особой чистоте воды! Электропроводность при 25 °C  $\leq 800$  микроСименс/см, коррозионная среда нейтральная.
- 5) Антифриз на базе этиленгликоля с ингибиторами. Содержание от 20% до 50% (например, антифриз N).

**Etanorm 32-125.1 - 32-250.1**

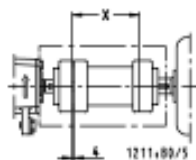
(Рис. А)



Размеры в мм

Etanorm	Двигатель об/мин				Типо- размер	Рисун- ок															 			
	1450	1750	2900	3500			DN <sub>1</sub>	DN <sub>2</sub>	a	b <sub>1</sub>	b <sub>2</sub>	b <sub>3</sub>	f	h <sub>1</sub>	h <sub>2</sub>	i	l <sub>1</sub>	l <sub>2</sub>	l <sub>3</sub>	l <sub>1</sub>	l <sub>2</sub>	l <sub>3</sub>	x	
32-125.1	0.55	0.55	-	-	80	A	50	32	80	450	240	300	360	212	140	100	860	650	710	950	740	800	100	
	-	-	0.55	-	71	A	50	32	80	450	240	300	360	212	140	100	860	650	710	950	740	800	100	
	-	-	0.75	-	80	A	50	32	80	450	240	300	360	212	140	100	860	650	710	950	740	800	100	
	-	-	1.1	1.1	80	A	50	32	80	450	240	300	360	212	140	100	860	650	710	950	740	800	100	
	-	-	1.5	1.5	90S	A	50	32	80	450	240	300	360	212	140	100	860	650	710	950	740	800	100	
	-	-	2.2	2.2	90L	A	50	32	80	450	240	300	360	212	140	100	950	740	800	1050	840	900	100	
	-	-	3.0	3.0	100L	A	50	32	80	450	240	300	360	212	140	100	1050	840	900	1150	940	1000	100	
	-	-	-	4.0	112M	A	50	32	80	450	240	300	360	212	140	100	1050	840	900	1150	940	1000	100	
32-160.1	0.55	0.55	-	-	80	A	50	32	80	450	240	300	360	232	160	100	860	650	710	950	740	800	100	
	-	0.75	-	-	80	A	50	32	80	450	240	300	360	232	160	100	860	650	710	950	740	800	100	
	-	1.1	-	-	90S	A	50	32	80	450	240	300	360	232	160	100	860	650	710	950	740	800	100	
	-	-	1.5	-	90S	A	50	32	80	450	240	300	360	232	160	100	860	650	710	950	740	800	100	
	-	-	2.2	2.2	90L	A	50	32	80	450	240	300	360	232	160	100	950	740	800	1050	840	900	100	
	-	-	3.0	3.0	100L	A	50	32	80	450	240	300	360	232	160	100	1050	840	900	1150	940	1000	100	
	-	-	4.0	4.0	112M	A	50	32	80	450	240	300	360	232	160	100	1050	840	900	1150	940	1000	100	
	-	-	-	5.5	132S	A	50	32	80	450	240	300	360	232	160	100	1050	840	900	1150	940	1000	100	
32-200.1	0.55	-	-	-	80	A	50	32	80	450	240	300	360	260	180	100	860	650	710	950	740	800	100	
	0.75	0.75	-	-	80	A	50	32	80	450	240	300	360	260	180	100	860	650	710	950	740	800	100	
	1.1	1.1	-	-	90S	A	50	32	80	450	240	300	360	260	180	100	860	650	710	950	740	800	100	
	-	1.5	-	-	90L	A	50	32	80	450	240	300	360	260	180	100	950	740	800	1050	840	900	100	
	-	2.2	-	-	100L	A	50	32	80	450	240	300	360	260	180	100	1050	840	900	1150	940	1000	100	
	-	-	3.0	-	100L	A	50	32	80	450	240	300	360	260	180	100	1050	840	900	1150	940	1000	100	
	-	-	4.0	-	112M	A	50	32	80	450	240	300	360	260	180	100	1050	840	900	1150	940	1000	100	
	-	-	5.5	5.5	132S	A	50	32	80	450	240	300	360	260	180	100	1050	840	900	1150	940	1000	100	
32-250.1	0.75	-	-	-	80	A	50	32	100	500	280	350	360	280	225	112	1050	840	900	1050	840	900	100	
	1.1	1.1	-	-	90S	A	50	32	100	500	280	350	360	280	225	112	1050	840	900	1050	840	900	100	
	1.5	1.5	-	-	90L	A	50	32	100	500	280	350	360	280	225	112	1050	840	900	1050	840	900	100	
	2.2	2.2	-	-	100L	A	50	32	100	500	280	350	360	280	225	112	1050	840	900	1050	840	900	100	
	-	3.0	-	-	100L	A	50	32	100	500	280	350	360	280	225	112	1050	840	900	1050	840	900	100	
	-	-	5.5	-	132S	A	50	32	100	500	280	350	360	280	225	112	1050	840	900	1150	940	1000	100	
	-	-	7.5	-	132S	A	50	32	100	500	280	350	360	280	225	112	1050	840	900	1150	940	1000	100	
	-	-	11.0	-	160M	A	50	32	100	500	280	350	360	280	225	112	1270	1060	1120	1270	1060	1120	100	



Etanorm 32-125 - 32-250

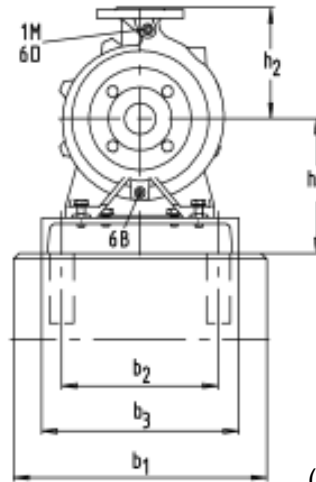
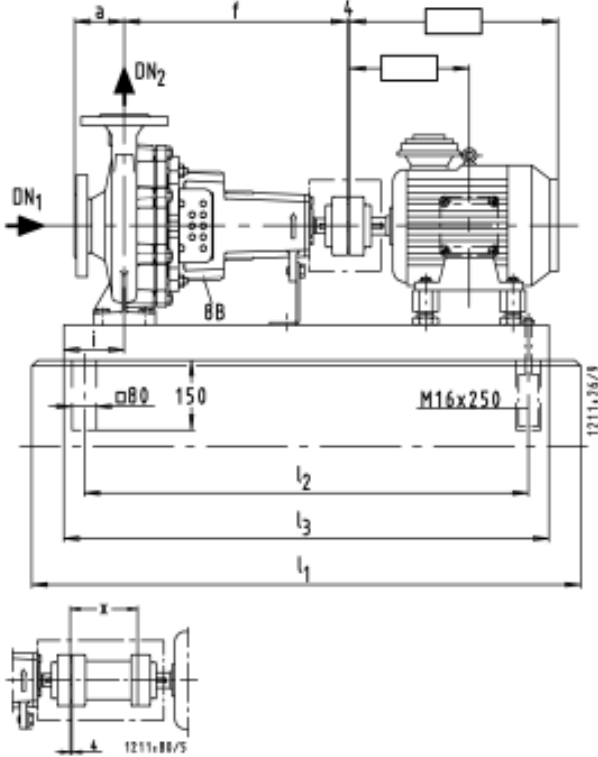

(Рис. А)

Размер в мм

Etanorm	Двигатель об/мин				Рису- нок																			
	1450	1750	2900	3500																				
	кВт				Типо- размер	DN <sub>1</sub>	DN <sub>2</sub>	a	b <sub>1</sub>	b <sub>2</sub>	b <sub>3</sub>	f	h <sub>1</sub>	h <sub>2</sub>	i	l <sub>1</sub>	l <sub>2</sub>	l <sub>3</sub>	l <sub>1</sub>	l <sub>2</sub>	l <sub>3</sub>	x		
32-125	0.55	0.55	-	-		80	A	50	32	80	450	240	300	360	212	140	100	860	650	710	950	740	800	100
	-	0.75	-	-	80	A	50	32	80	450	240	300	360	212	140	100	860	650	710	950	740	800	100	
	-	-	1.1	1.5	90S	A	50	32	80	450	240	300	360	212	140	100	860	650	710	950	740	800	100	
	-	-	2.2	2.2	90L	A	50	32	80	450	240	300	360	212	140	100	950	740	800	1050	840	900	100	
	-	-	3.0	3.0	100L	A	50	32	80	450	240	300	360	212	140	100	1050	840	900	1150	940	1000	100	
	-	-	4.0	4.0	112M	A	50	32	80	450	240	300	360	212	140	100	1050	840	900	1150	940	1000	100	
	-	-	5.5	5.5	132S	A	50	32	80	450	240	300	360	232	140	100	1050	840	900	1150	940	1000	100	
	32-160	0.55	0.55	-	-	80	A	50	32	80	450	240	300	360	232	160	100	860	650	710	950	740	800	100
		-	0.75	-	-	80	A	50	32	80	450	240	300	360	232	160	100	860	650	710	950	740	800	100
		-	1.1	-	-	90S	A	50	32	80	450	240	300	360	232	160	100	860	650	710	950	740	800	100
-		-	2.2	2.2	90L	A	50	32	80	450	240	300	360	232	160	100	950	740	800	1050	840	900	100	
-		-	3.0	3.0	100L	A	50	32	80	450	240	300	360	232	160	100	1050	840	900	1150	940	1000	100	
-		-	4.0	4.0	112M	A	50	32	80	450	240	300	360	232	160	100	1050	840	900	1150	940	1000	100	
-		-	5.5	5.5	132S	A	50	32	80	450	240	300	360	232	160	100	1050	840	900	1150	940	1000	100	
-		-	7.5	7.5	132S	A	50	32	80	450	240	300	360	232	160	100	1050	840	900	1150	940	1000	100	
32-200		0.55	-	-	-	80	A	50	32	80	450	240	300	360	260	180	100	860	650	710	950	740	800	100
		0.75	-	-	-	80	A	50	32	80	450	240	300	360	260	180	100	860	650	710	950	740	800	100
	1.1	1.1	-	-	90S	A	50	32	80	450	240	300	360	260	180	100	860	650	710	950	740	800	100	
	-	1.5	-	-	90L	A	50	32	80	450	240	300	360	260	180	100	950	740	800	1050	840	900	100	
	-	2.2	-	-	100L	A	50	32	80	450	240	300	360	260	180	100	1050	840	900	1150	940	1000	100	
	-	-	4.0	-	112M	A	50	32	80	450	240	300	360	260	180	100	1050	840	900	1150	940	1000	100	
	-	-	5.5	-	132S	A	50	32	80	450	240	300	360	260	180	100	1050	840	900	1150	940	1000	100	
	-	-	7.5	7.5	132S	A	50	32	80	450	240	300	360	260	180	100	1050	840	900	1150	940	1000	100	
	-	-	11.0	11.0	160M	A	50	32	80	500	280	350	360	260	180	100	1270	1060	1120	1270	1060	1120	100	
	-	-	15.0	15.0	160M	A	50	32	80	500	280	350	360	260	180	100	1270	1060	1120	1270	1060	1120	100	
32-250	1.1	-	-	-	90S	A	50	32	100	500	280	350	360	280	225	112	1050	840	900	1050	840	900	100	
	1.5	1.5	-	-	90L	A	50	32	100	500	280	350	360	280	225	112	1050	840	900	1050	840	900	100	
	2.2	2.2	-	-	100L	A	50	32	100	500	280	350	360	280	225	112	1050	840	900	1050	840	900	100	
	-	3.0	-	-	100L	A	50	32	100	500	280	350	360	280	225	112	1050	840	900	1050	840	900	100	
	-	4.0	-	-	112M	A	50	32	100	500	280	350	360	280	225	112	1050	840	900	1050	840	900	100	
	-	5.5	-	-	132S	A	50	32	100	500	280	350	360	280	225	112	1050	840	900	1150	940	1000	100	
	-	-	7.5	-	132S	A	50	32	100	500	280	350	360	280	225	112	1050	840	900	1150	940	1000	100	
	-	-	11.0	-	160M	A	50	32	100	500	280	350	360	280	225	112	1270	1060	1120	1270	1060	1120	100	
	-	-	15.0	-	160M	A	50	32	100	500	280	350	360	280	225	112	1270	1060	1120	1270	1060	1120	100	

## Etanorm 40-125 - 40-315

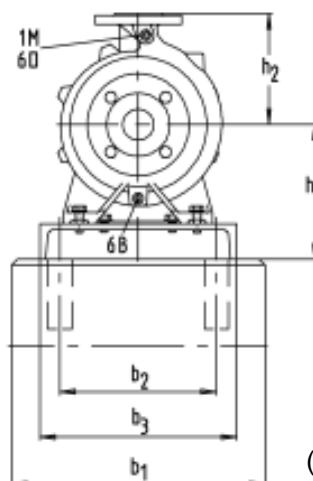
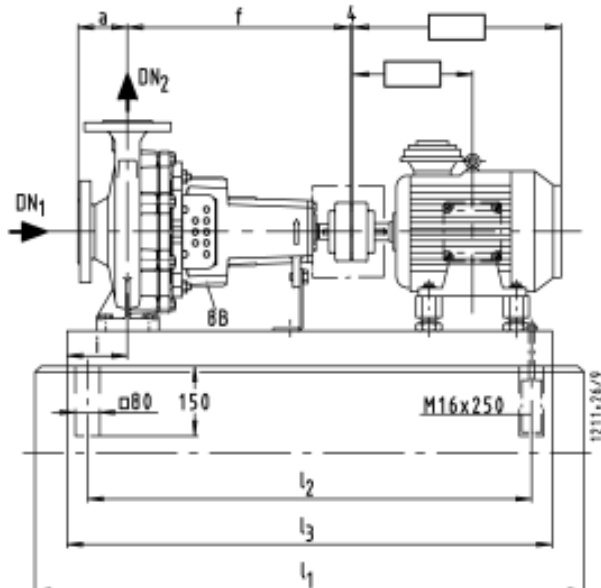

(Рис. А)

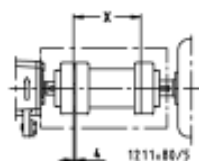

Размеры в мм

Etanorm	Двигатель об/мин				Типо- размер	Рису- нок																	
	1450	1750	2900	3500			кВт																
							DN <sub>1</sub>	DN <sub>2</sub>	a	b <sub>1</sub>	b <sub>2</sub>	b <sub>3</sub>	f	h <sub>1</sub>	h <sub>2</sub>	i	l <sub>1</sub>	l <sub>2</sub>	l <sub>3</sub>	l <sub>1</sub>	l <sub>2</sub>	l <sub>3</sub>	x
40-125	0.55	0.55	-	-	80	A	65	40	80	450	240	300	360	212	140	100	860	650	710	950	740	800	100
	-	1.1	-	-	80	A	65	40	80	450	240	300	360	212	140	100	860	650	710	950	740	800	100
	-	-	1.5	-	90S	A	65	40	80	450	240	300	360	212	140	100	860	650	710	950	740	800	100
	-	-	2.2	-	90L	A	65	40	80	450	240	300	360	212	140	100	950	740	800	1050	840	900	100
	-	-	3.0	-	100L	A	65	40	80	450	240	300	360	212	140	100	1050	840	900	1150	940	1000	100
	-	-	4.0	-	112M	A	65	40	80	450	240	300	360	212	140	100	1050	840	900	1150	940	1000	100
	-	-	5.5	-	132S	A	65	40	80	450	240	300	360	232	140	100	1050	840	900	1150	940	1000	100
	-	-	7.5	-	132S	A	65	40	80	450	240	300	360	232	140	100	1050	840	900	1150	940	1000	100
	-	-	11.0	-	160M	A	65	40	80	500	280	350	360	260	140	100	1150	940	1000	1270	1060	1120	100
	40-160	0.55	-	-	-	80	A	65	40	80	450	240	300	360	232	160	100	860	650	710	950	740	800
0.75		0.75	-	-	80	A	65	40	80	450	240	300	360	232	160	100	860	650	710	950	740	800	100
1.1		1.1	-	-	90S	A	65	40	80	450	240	300	360	232	160	100	860	650	710	950	740	800	100
-		1.5	-	-	90L	A	65	40	80	450	240	300	360	232	160	100	950	740	800	1050	840	900	100
-		2.2	-	-	100L	A	65	40	80	450	240	300	360	232	160	100	1050	840	900	1150	940	1000	100
-		-	3.0	-	100L	A	65	40	80	450	240	300	360	232	160	100	1050	840	900	1150	940	1000	100
-		-	4.0	-	112M	A	65	40	80	450	240	300	360	232	160	100	1050	840	900	1150	940	1000	100
-		-	5.5	-	132S	A	65	40	80	450	240	300	360	232	160	100	1050	840	900	1150	940	1000	100
-		-	7.5	-	132S	A	65	40	80	450	240	300	360	232	160	100	1050	840	900	1150	940	1000	100
-		-	11.0	-	160M	A	65	40	80	500	280	350	360	260	160	100	1270	1060	1120	1270	1060	1120	100
40-200	0.75	-	-	-	80	A	65	40	100	450	240	300	360	260	180	100	860	650	710	950	740	800	100
	1.1	-	-	-	90S	A	65	40	100	450	240	300	360	260	180	100	860	650	710	950	740	800	100
	1.5	1.5	-	-	90L	A	65	40	100	450	240	300	360	260	180	100	950	740	800	1050	840	900	100
	-	2.2	-	-	100L	A	65	40	100	450	240	300	360	260	180	100	1050	840	900	1150	940	1000	100
	-	3.0	-	-	100L	A	65	40	100	450	240	300	360	260	180	100	1050	840	900	1150	940	1000	100
	-	-	5.5	-	132S	A	65	40	100	450	240	300	360	260	180	100	1050	840	900	1150	940	1000	100
	-	-	7.5	-	132S	A	65	40	100	450	240	300	360	260	180	100	1050	840	900	1150	940	1000	100
	-	-	11.0	-	160M	A	65	40	100	500	280	350	360	260	180	100	1270	1060	1120	1270	1060	1120	100
	-	-	15.0	-	160M	A	65	40	100	500	280	350	360	260	180	100	1270	1060	1120	1270	1060	1120	100
	-	-	18.5	-	160L	A	65	40	100	500	280	350	360	260	180	100	1270	1060	1120	1400	1190	1250	100
40-250	1.1	-	-	-	90S	A	65	40	100	500	280	350	360	280	225	112	1050	840	900	1050	840	900	100
	1.5	-	-	-	90L	A	65	40	100	500	280	350	360	280	225	112	1050	840	900	1050	840	900	100
	2.2	2.2	-	-	100L	A	65	40	100	500	280	350	360	280	225	112	1050	840	900	1050	840	900	100
	3.0	3.0	-	-	100L	A	65	40	100	500	280	350	360	280	225	112	1050	840	900	1050	840	900	100
	-	4.0	-	-	112M	A	65	40	100	500	280	350	360	280	225	112	1050	840	900	1050	840	900	100
	-	5.5	-	-	132S	A	65	40	100	500	280	350	360	280	225	112	1050	840	900	1150	940	1000	100
	-	-	11.0	-	160M	A	65	40	100	500	280	350	360	280	225	112	1270	1060	1120	1270	1060	1120	100
	-	-	15.0	-	160M	A	65	40	100	500	280	350	360	280	225	112	1270	1060	1120	1270	1060	1120	100
	-	-	18.5	-	160L	A	65	40	100	500	280	350	360	280	225	112	1270	1060	1120	1400	1190	1250	100
	-	-	22.0	-	180M	A	65	40	100	550	320	400	360	290	225	112	1400	1190	1250	1400	1190	1250	100
40-315	2.2	-	-	-	100L	A	65	40	125	500	280	350	470	325	250	112	1050	840	900	1150	940	1000	100
	3.0	-	-	-	100L	A	65	40	125	500	280	350	470	325	250	112	1050	840	900	1150	940	1000	100
	4.0	-	-	-	112M	A	65	40	125	500	280	350	470	325	250	112	1150	940	1000	1270	1060	1120	100
	5.5	5.5	-	-	132S	A	65	40	125	500	280	350	470	325	250	112	1150	940	1000	1270	1060	1120	100
	-	7.5	-	-	132M	A	65	40	125	500	280	350	470	325	250	112	1270	1060	1120	1270	1060	1120	100
	-	11.0	-	-	160M	A	65	40	125	550	320	400	470	335	250	112	1400	1190	1250	1400	1190	1250	100

## Etanorm 50-125 - 50-315



Рис. А

Размеры в мм

Etanorm	Двигатель об/мин				Типо- размер	Рису- нок																	
	кВт						DN <sub>1</sub>	DN <sub>2</sub>	a	b <sub>1</sub>	b <sub>2</sub>	b <sub>3</sub>	f	h <sub>1</sub>	h <sub>2</sub>	i	l <sub>1</sub>	l <sub>2</sub>	l <sub>3</sub>	l <sub>1</sub>	l <sub>2</sub>	l <sub>3</sub>	x
	1450	1750	2900	3500																			
50-125	0.55	-	-	-	80	A	65	50	100	450	240	300	360	232	160	100	860	650	710	950	740	800	100
	0.75	0.75	-	-	80	A	65	50	100	450	240	300	360	232	160	100	860	650	710	950	740	800	100
	-	1.1	-	-	90S	A	65	50	100	450	240	300	360	232	160	100	860	650	710	950	740	800	100
	-	-	1.5	-	90L	A	65	50	100	450	240	300	360	232	160	100	950	740	800	1050	840	900	100
	-	-	-	3.0	100L	A	65	50	100	450	240	300	360	232	160	100	1050	840	900	1150	940	1000	100
	-	-	-	4.0	112M	A	65	50	100	450	240	300	360	232	160	100	1050	840	900	1150	940	1000	100
	-	-	-	5.5	132S	A	65	50	100	450	240	300	360	232	160	100	1050	840	900	1150	940	1000	100
	-	-	-	7.5	132S	A	65	50	100	450	240	300	360	232	160	100	1050	840	900	1150	940	1000	100
	-	-	-	11.0	160M	A	65	50	100	500	280	350	360	260	160	100	1270	1060	1120	1270	1060	1120	100
	-	-	-	15.0	160M	A	65	50	100	500	280	350	360	260	160	100	1270	1060	1120	1270	1060	1120	100
50-160	0.75	-	-	-	80	A	65	50	100	450	240	300	360	260	180	100	860	650	710	950	740	800	100
	1.1	1.1	-	-	90S	A	65	50	100	450	240	300	360	260	180	100	860	650	710	950	740	800	100
	-	1.5	-	-	90L	A	65	50	100	450	240	300	360	260	180	100	950	740	800	1050	840	900	100
	-	-	2.2	-	100L	A	65	50	100	450	240	300	360	260	180	100	1050	840	900	1150	940	1000	100
	-	-	3.0	-	100L	A	65	50	100	450	240	300	360	260	180	100	1050	840	900	1150	940	1000	100
	-	-	-	5.5	132S	A	65	50	100	450	240	300	360	260	180	100	1050	840	900	1150	940	1000	100
	-	-	-	7.5	132S	A	65	50	100	450	240	300	360	260	180	100	1050	840	900	1150	940	1000	100
	-	-	-	11.0	160M	A	65	50	100	500	280	350	360	260	180	100	1270	1060	1120	1270	1060	1120	100
	-	-	-	15.0	160M	A	65	50	100	500	280	350	360	260	180	100	1270	1060	1120	1270	1060	1120	100
	-	-	-	18.5	160L	A	65	50	100	500	280	350	360	260	180	100	1270	1060	1120	1400	1190	1250	100
50-200	1.5	-	-	-	90L	A	65	50	100	450	240	300	360	260	200	100	950	740	800	1050	840	900	100
	2.2	2.2	-	-	100L	A	65	50	100	450	240	300	360	260	200	100	1050	840	900	1150	940	1000	100
	-	3.0	-	-	100L	A	65	50	100	450	240	300	360	260	200	100	1050	840	900	1150	940	1000	100
	-	-	4.0	-	112M	A	65	50	100	450	240	300	360	260	200	100	1050	840	900	1150	940	1000	100
	-	-	5.5	-	132S	A	65	50	100	450	240	300	360	260	200	100	1050	840	900	1150	940	1000	100
	-	-	-	11.0	160M	A	65	50	100	500	280	350	360	260	200	100	1270	1060	1120	1270	1060	1120	100
	-	-	-	15.0	160M	A	65	50	100	500	280	350	360	260	200	100	1270	1060	1120	1270	1060	1120	100
	-	-	-	18.5	160L	A	65	50	100	500	280	350	360	260	200	100	1270	1060	1120	1400	1190	1250	100
	-	-	-	22.0	180M	A	65	50	100	550	320	400	360	290	200	100	1400	1190	1250	1400	1190	1250	100
	-	-	-	30.0	200L	A	65	50	100	550	320	400	360	310	200	100	1400	1190	1250	1400	1190	1250	100
50-250	2.2	-	-	-	100L	A	65	50	100	500	280	350	360	280	225	112	1050	840	900	1050	840	900	100
	3.0	-	-	-	100L	A	65	50	100	500	280	350	360	280	225	112	1050	840	900	1050	840	900	100
	-	4.0	-	-	112M	A	65	50	100	500	280	350	360	280	225	112	1050	840	900	1050	840	900	100
	-	-	5.5	-	132S	A	65	50	100	500	280	350	360	280	225	112	1050	840	900	1150	940	1000	100
	-	-	7.5	-	132M	A	65	50	100	500	280	350	360	280	225	112	1150	940	1000	1270	1060	1120	100
	-	-	11.0	-	160M	A	65	50	100	500	280	350	360	280	225	112	1270	1060	1120	1270	1060	1120	100
	-	-	-	15.0	160M	A	65	50	100	500	280	350	360	280	225	112	1270	1060	1120	1270	1060	1120	100
	-	-	-	18.5	160L	A	65	50	100	500	280	350	360	280	225	112	1270	1060	1120	1400	1190	1250	100
	-	-	-	22.0	180M	A	65	50	100	550	320	400	360	290	225	112	1400	1190	1250	1400	1190	1250	100
	-	-	-	30.0	200L	A	65	50	100	550	320	400	360	310	225	112	1400	1190	1250	1400	1190	1250	100
50-315	3.0	-	-	-	100L	A	65	50	125	500	280	350	470	325	250	112	1050	840	900	1150	940	1000	100
	4.0	-	-	-	112M	A	65	50	125	500	280	350	470	325	250	112	1150	940	1000	1270	1060	1120	100
	-	5.5	-	-	132S	A	65	50	125	500	280	350	470	325	250	112	1150	940	1000	1270	1060	1120	100
	-	7.5	7.5	-	132M	A	65	50	125	500	280	350	470	325	250	112	1270	1060	1120	1270	1060	1120	100
	-	-	11.0	-	160M	A	65	50	125	550	320	400	470	335	250	112	1400	1190	1250	1400	1190	1250	100
	-	-	15.0	-	160L	A	65	50	125	550	320	400	470	335	250	112	1400	1190	1250	1400	1190	1250	100

## Etanorm 65-125 - 65-200

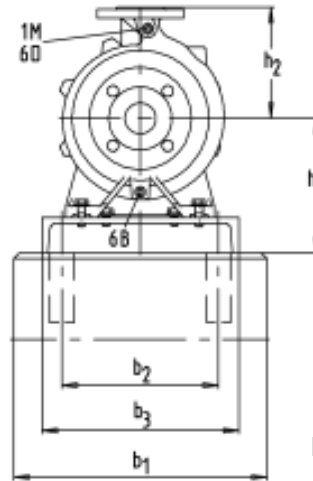
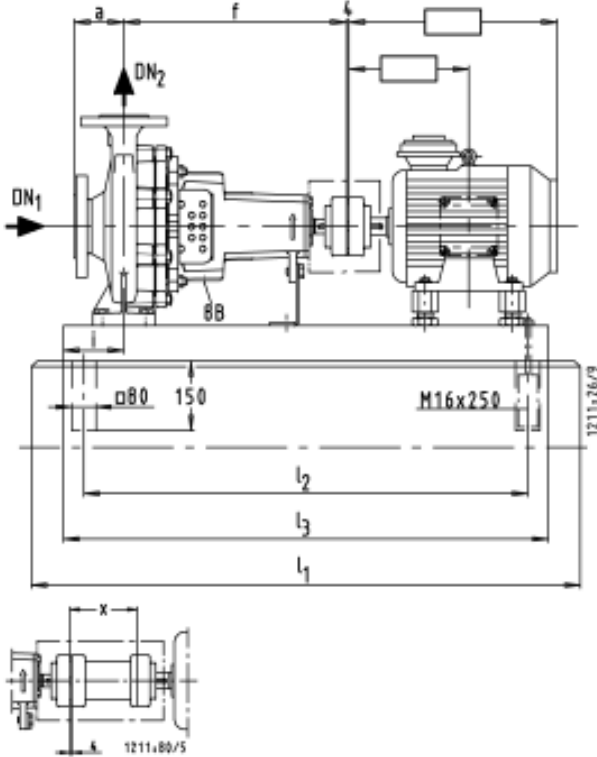

Рис. А



Размеры в мм

Etanorm	Двигатель				Типо-размер	Рису-нок																					
	1450	1750	2900	3500			DN <sub>1</sub>	DN <sub>2</sub>	a	b <sub>1</sub>	b <sub>2</sub>	b <sub>3</sub>	f	h <sub>1</sub>	h <sub>2</sub>	i	l <sub>1</sub>	l <sub>2</sub>	l <sub>3</sub>	l <sub>1</sub>	l <sub>2</sub>	l <sub>3</sub>	x				
65-125	0.55	-	-	-	80	A	80	65	100	450	240	300	360	260	180	112	860	650	710	950	740	800	100				
	0.75	-	-	-	80	A	80	65	100	450	240	300	360	260	180	112	860	650	710	950	740	800	100				
	1.1	1.1	-	-	90S	A	80	65	100	450	240	300	360	260	180	112	860	650	710	950	740	800	100				
	-	1.5	-	-	90L	A	80	65	100	450	240	300	360	260	180	112	950	740	800	1050	840	900	100				
	-	2.2	-	-	100L	A	80	65	100	450	240	300	360	260	180	112	1050	840	900	1150	940	1000	100				
	-	-	4.0	-	112M	A	80	65	100	450	240	300	360	260	180	112	1050	840	900	1150	940	1000	100				
	-	-	5.5	-	132S	A	80	65	100	450	240	300	360	260	180	112	1050	840	900	1150	940	1000	100				
	-	-	7.5	7.5	132S	A	80	65	100	450	240	300	360	260	180	112	1050	840	900	1150	940	1000	100				
	-	-	11.0	11.0	160M	A	80	65	100	500	280	350	360	260	180	112	1270	1060	1120	1270	1060	1120	100				
	-	-	15.0	15.0	160M	A	80	65	100	500	280	350	360	260	180	112	1270	1060	1120	1270	1060	1120	100				
65-160	1.1	-	-	-	90S	A	80	65	100	450	240	300	360	260	200	112	860	650	710	950	740	800	100				
	1.5	1.5	-	-	90L	A	80	65	100	450	240	300	360	260	200	112	950	740	800	1050	840	900	100				
	2.2	2.2	-	-	100L	A	80	65	100	450	240	300	360	260	200	112	1050	840	900	1150	940	1000	100				
	-	3.0	-	-	100L	A	80	65	100	450	240	300	360	260	200	112	1050	840	900	1150	940	1000	100				
	-	4.0	-	-	112M	A	80	65	100	450	240	300	360	260	200	112	1050	840	900	1150	940	1000	100				
	-	-	7.5	-	132S	A	80	65	100	450	240	300	360	260	200	112	1050	840	900	1150	940	1000	100				
	-	-	11.0	-	160M	A	80	65	100	500	280	350	360	260	200	112	1270	1060	1120	1270	1060	1120	100				
	-	-	15.0	15.0	160M	A	80	65	100	500	280	350	360	260	200	112	1270	1060	1120	1270	1060	1120	100				
	-	-	18.5	18.5	160L	A	80	65	100	500	280	350	360	260	200	112	1270	1060	1120	1400	1190	1250	100				
	-	-	22.0	22.0	180M	A	80	65	100	550	320	400	360	290	200	112	1400	1190	1250	1400	1190	1250	100				
65-200	2.2	-	-	-	100L	A	80	65	100	500	280	350	360	280	225	112	1050	840	900	1150	940	1000	140				
	3.0	3.0	-	-	100L	A	80	65	100	500	280	350	360	280	225	112	1050	840	900	1150	940	1000	140				
	4.0	4.0	-	-	112M	A	80	65	100	500	280	350	360	280	225	112	1050	840	900	1150	940	1000	140				
	-	5.5	-	-	132S	A	80	65	100	500	280	350	360	280	225	112	1050	840	900	1150	940	1000	140				
	-	7.5	-	-	132M	A	80	65	100	500	280	350	360	280	225	112	1150	940	1000	1270	1060	1120	140				
	-	-	15.0	-	160M	A	80	65	100	500	280	350	360	280	225	112	1270	1060	1120	1400	1190	1250	140				
	-	-	18.5	-	160L	A	80	65	100	500	280	350	360	280	225	112	1270	1060	1120	1400	1190	1250	140				
	-	-	22.0	22.0	180M	A	80	65	100	550	320	400	360	290	225	112	1400	1190	1250	1400	1190	1250	140				
	-	-	30.0	30.0	200L	A	80	65	100	550	320	400	360	310	225	112	1400	1190	1250	1400	1190	1250	140				
	-	-	-	37.0	200L	A	80	65	100	550	320	400	360	310	225	112	1400	1190	1250	1400	1190	1250	140				

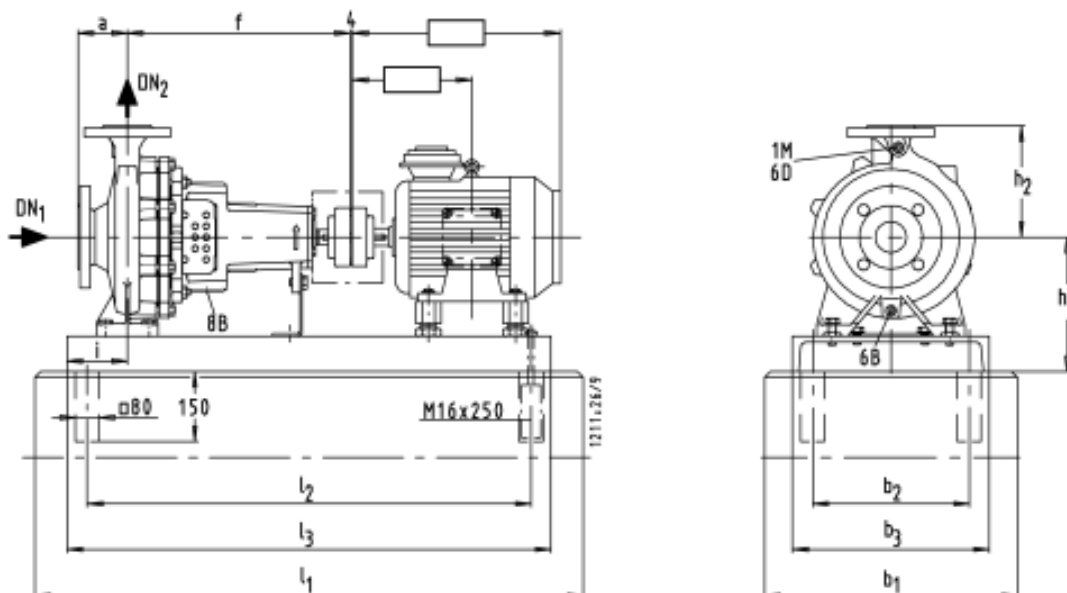
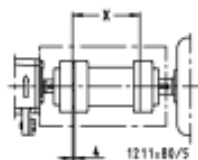
Etanorm 65-250 - 65-315



Рис. А



Рис. В

Размеры в мм

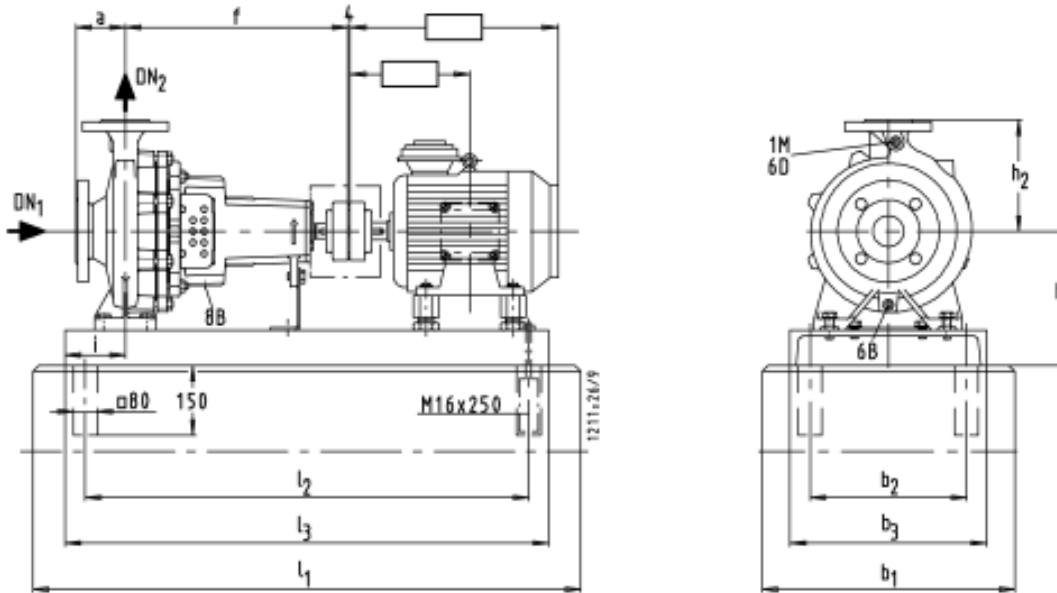
Etanorm	Двигатель об/мин				Типо- размер	Рису- нок																	
	1450	1750	2900	3500																			
	кВт						DN <sub>1</sub>	DN <sub>2</sub>	a	b <sub>1</sub>	b <sub>2</sub>	b <sub>3</sub>	f	h <sub>1</sub>	h <sub>2</sub>	i	l <sub>1</sub>	l <sub>2</sub>	l <sub>3</sub>	l <sub>1</sub>	l <sub>2</sub>	l <sub>3</sub>	x
65-250	3.0	-	-	-	100L	A	80	65	100	550	320	400	470	310	250	130	1150	940	1000	1400	1190	1250	140
	4.0	-	-	-	112M	A	80	65	100	550	320	400	470	310	250	130	1150	940	1000	1400	1190	1250	140
	5.5	5.5	-	-	132S	A	80	65	100	550	320	400	470	310	250	130	1150	940	1000	1400	1190	1250	140
	-	7.5	-	-	132M	A	80	65	100	550	320	400	470	310	250	130	1150	940	1000	1400	1190	1250	140
	-	11.0	-	-	160M	A	80	65	100	550	320	400	470	310	250	130	1400	1190	1250	1570	1360	1420	140
	-	-	22.0	-	180M	A	80	65	100	550	320	400	470	310	250	130	1400	1190	1250	1570	1360	1420	140
	-	-	30.0	-	200L	A	80	65	100	550	320	400	470	310	250	130	1400	1190	1250	1570	1360	1420	140
	-	-	37.0	-	200L	A	80	65	100	550	320	400	470	310	250	130	1400	1190	1250	1570	1360	1420	140
-	-	45.0	-	225M	B	80	65	100	750	550	590	470	365	250	130	1550	940	1400	1550	940	1400	140	
65-315	5.5	-	-	-	132S	A	80	65	125	550	320	400	470	335	280	130	1150	940	1000	1400	1190	1250	140
	7.5	-	-	-	132M	A	80	65	125	550	320	400	470	335	280	130	1150	940	1000	1400	1190	1250	140
	11.0	11.0	-	-	160M	A	80	65	125	550	320	400	470	335	280	130	1400	1190	1250	1570	1360	1420	140
	-	15.0	-	-	160L	A	80	65	125	550	320	400	470	335	280	130	1400	1190	1250	1570	1360	1420	140
	-	18.5	-	-	180M	A	80	65	125	550	320	400	470	335	280	130	1400	1190	1250	1570	1360	1420	140
	-	22.0	-	-	180L	A	80	65	125	550	320	400	470	335	280	130	1400	1190	1250	1570	1360	1420	140

## Etanorm 80-160 - 80-250

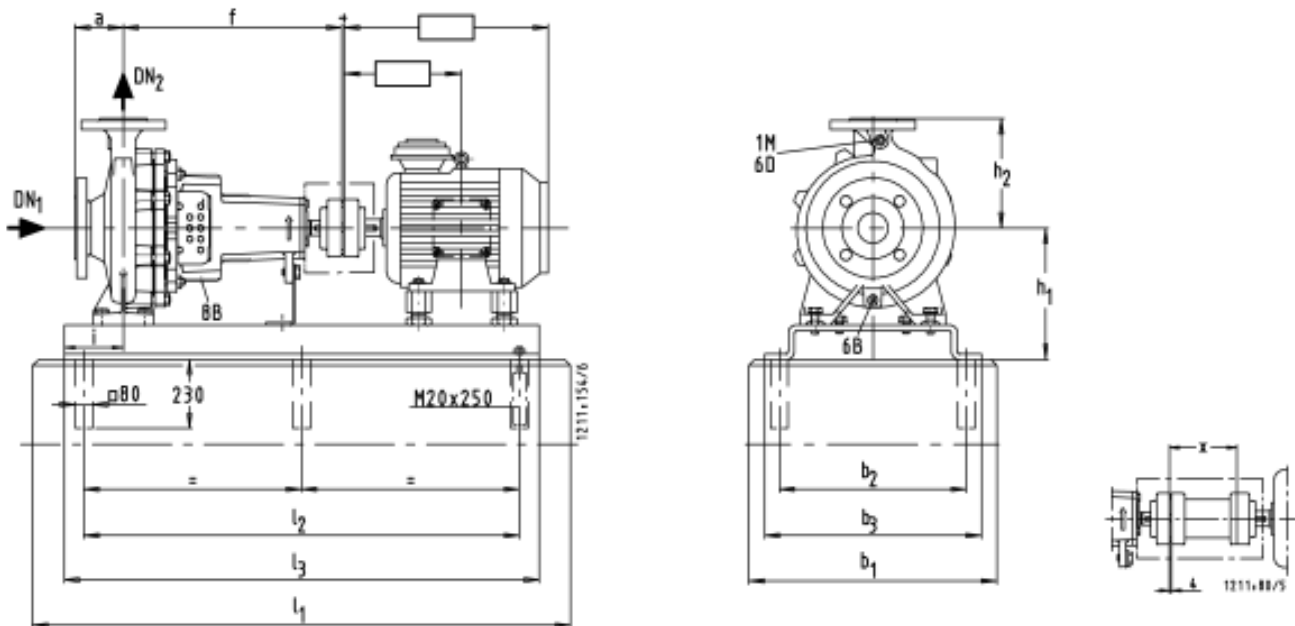

Рис. А



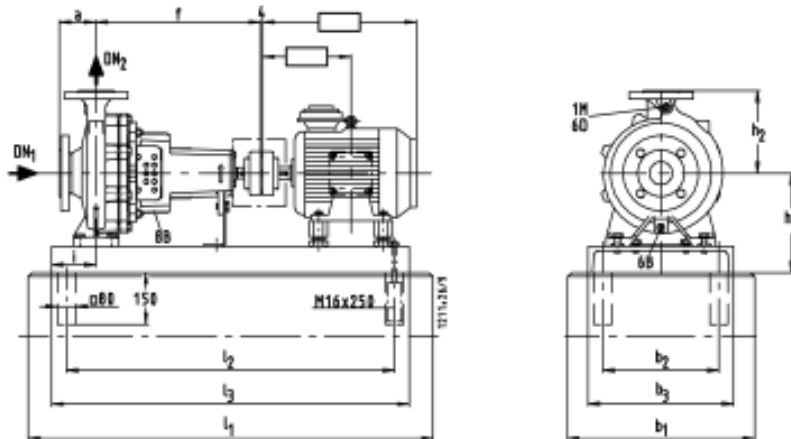

Рис. В

Размеры в мм

Etanorm	Двигатель об/мин				Типо- размер	Рису- нок																		
	1450	1750	2900	3500			кВт	DN <sub>1</sub>	DN <sub>2</sub>	a	b <sub>1</sub>	b <sub>2</sub>	b <sub>3</sub>	f	h <sub>1</sub>	h <sub>2</sub>	l	l <sub>1</sub>	l <sub>2</sub>	l <sub>3</sub>	l <sub>1</sub>	l <sub>2</sub>	l <sub>3</sub>	x
80-160	1.5	-	-	-	90L	A	100	80	125	500	280	350	360	280	225	112	1050	840	900	1050	840	900	140	
	2.2	-	-	-	100L	A	100	80	125	500	280	350	360	280	225	112	1050	840	900	1150	940	1000	140	
	3.0	3.0	-	-	100L	A	100	80	125	500	280	350	360	280	225	112	1050	840	900	1150	940	1000	140	
	-	4.0	-	-	112M	A	100	80	125	500	280	350	360	280	225	112	1050	840	900	1150	940	1000	140	
	-	5.5	-	-	132S	A	100	80	125	500	280	350	360	280	225	112	1050	840	900	1150	940	1000	140	
	-	-	15.0	-	160M	A	100	80	125	500	280	350	360	280	225	112	1270	1060	1120	1400	1190	1250	140	
	-	-	18.5	-	160L	A	100	80	125	500	280	350	360	280	225	112	1270	1060	1120	1400	1190	1250	140	
	-	-	22.0	22.0	180M	A	100	80	125	550	320	400	360	290	225	112	1400	1190	1250	1400	1190	1250	140	
	-	-	30.0	30.0	200L	A	100	80	125	550	320	400	360	310	225	112	1400	1190	1250	1400	1190	1250	140	
	-	-	37.0	37.0	200L	A	100	80	125	550	320	400	360	310	225	112	1400	1190	1250	1400	1190	1250	140	
80-200	2.2	-	-	-	100L	A	100	80	125	500	280	350	470	280	250	112	1150	940	1000	1270	1060	1120	140	
	3.0	-	-	-	100L	A	100	80	125	500	280	350	470	280	250	112	1150	940	1000	1270	1060	1120	140	
	4.0	-	-	-	112M	A	100	80	125	500	280	350	470	280	250	112	1150	940	1000	1270	1060	1120	140	
	5.5	5.5	-	-	132S	A	100	80	125	500	280	350	470	280	250	112	1150	940	1000	1270	1060	1120	140	
	-	7.5	-	-	132M	A	100	80	125	500	280	350	470	280	250	112	1270	1060	1120	1400	1190	1250	140	
	-	11.0	-	-	160M	A	100	80	125	500	280	350	470	280	250	112	1270	1060	1120	1400	1190	1250	140	
	-	-	18.5	-	160L	A	100	80	125	550	320	400	470	290	250	112	1400	1190	1250	1570	1360	1420	140	
	-	-	22.0	-	180M	A	100	80	125	550	320	400	470	290	250	112	1400	1190	1250	1570	1360	1420	140	
	-	-	30.0	-	200L	A	100	80	125	550	320	400	470	310	250	112	1400	1190	1250	1570	1360	1420	140	
	-	-	37.0	-	200L	A	100	80	125	550	320	400	470	310	250	112	1400	1190	1250	1570	1360	1420	140	
-	-	45.0	45.0	225M	B	100	80	125	750	550	590	470	365	250	112	1550	940	1400	1550	940	1400	140		
-	-	55.0	55.0	250M	B	100	80	125	810	600	650	470	390	250	112	1750	1060	1600	1750	1060	1600	140		
-	-	75.0	75.0	280S	B	100	80	125	880	670	720	470	420	250	112	1750	1060	1600	1750	1060	1600	140		
80-250	4.0	-	-	-	112M	A	100	80	125	550	320	400	470	310	280	130	1150	940	1000	1400	1190	1250	140	
	5.5	-	-	-	132S	A	100	80	125	550	320	400	470	310	280	130	1150	940	1000	1400	1190	1250	140	
	7.5	7.5	-	-	132M	A	100	80	125	550	320	400	470	310	280	130	1150	940	1000	1400	1190	1250	140	
	11.0	11.0	-	-	160M	A	100	80	125	550	320	400	470	310	280	130	1400	1190	1250	1570	1360	1420	140	
	-	15.0	-	-	160L	A	100	80	125	550	320	400	470	310	280	130	1400	1190	1250	1570	1360	1420	140	
	-	18.5	-	-	180M	A	100	80	125	550	320	400	470	310	280	130	1400	1190	1250	1570	1360	1420	140	
	-	-	30.0	-	200L	A	100	80	125	550	320	400	470	310	280	130	1400	1190	1250	1570	1360	1420	140	
	-	-	37.0	-	200L	A	100	80	125	550	320	400	470	310	280	130	1400	1190	1250	1570	1360	1420	140	
	-	-	45.0	-	225M	B	100	80	125	750	550	590	470	365	280	130	1550	940	1400	1550	940	1400	140	
	-	-	55.0	-	250M	B	100	80	125	810	600	650	470	390	280	130	1750	1060	1600	1750	1060	1600	140	
-	-	75.0	-	280S	B	100	80	125	880	670	720	470	420	280	130	1750	1060	1600	1750	1060	1600	140		

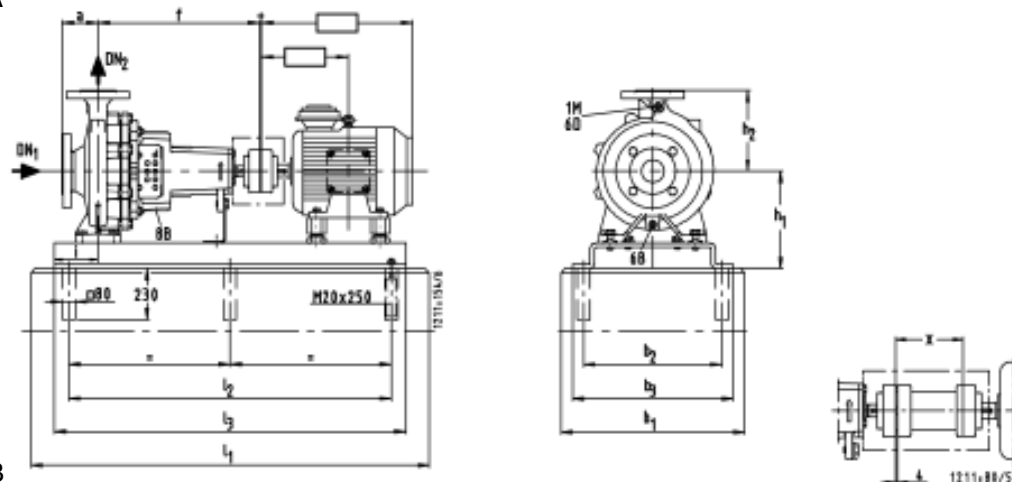
## Etanorm 80-315 - 80-400



Рис. А



Рис. В

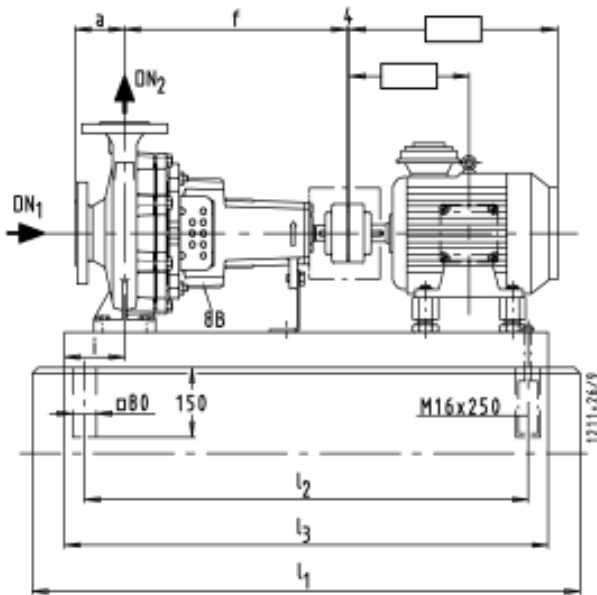

Размеры в мм

Etanorm	Двигатель ОБ/МИН кВт				Типо- размер	Рису- нок																	
	1450	1750	2900	3500			DN <sub>1</sub>	DN <sub>2</sub>	a	b <sub>1</sub>	b <sub>2</sub>	b <sub>3</sub>	f	h <sub>1</sub>	h <sub>2</sub>	i	l <sub>1</sub>	l <sub>2</sub>	l <sub>3</sub>	l <sub>1</sub>	l <sub>2</sub>	l <sub>3</sub>	x
80-315	7.5	-	-	-	132M	A	100	80	125	550	320	400	470	360	315	130	1150	940	1000	1400	1190	1250	140
	11.0	-	-	-	160M	A	100	80	125	550	320	400	470	360	315	130	1400	1190	1250	1570	1360	1420	140
	15.0	-	-	-	160L	A	100	80	125	550	320	400	470	360	315	130	1400	1190	1250	1570	1360	1420	140
	18.5	18.5	-	-	180M	A	100	80	125	550	320	400	470	360	315	130	1400	1190	1250	1570	1360	1420	140
	-	22.0	-	-	180L	A	100	80	125	550	320	400	470	360	315	130	1400	1190	1250	1570	1360	1420	140
	-	30.0	-	-	200L	B	100	80	125	750	550	590	470	390	315	130	1550	940	1400	1550	940	1400	140
80-400	-	37.0	-	-	225S	B	100	80	125	750	550	590	470	390	315	130	1550	940	1400	1550	940	1400	140
	11.0	-	-	-	160M	B	100	80	125	750	550	590	530	420	355	112	1550	940	1400	1550	940	1400	140
	15.0	-	-	-	160L	B	100	80	125	750	550	590	530	420	355	112	1550	940	1400	1550	940	1400	140
	18.5	-	-	-	180M	B	100	80	125	750	550	590	530	420	355	112	1550	940	1400	1550	940	1400	140
	22.0	-	-	-	180L	B	100	80	125	750	550	590	530	420	355	112	1550	940	1400	1550	940	1400	140
	30.0	30.0	-	-	200L	B	100	80	125	750	550	590	530	420	355	112	1550	940	1400	1550	940	1400	140
	-	37.0	-	-	225S	B	100	80	125	750	550	590	530	420	355	112	1550	940	1400	1550	940	1400	140
	-	45.0	-	-	225M	B	100	80	125	750	550	590	530	420	355	112	1550	940	1400	1550	940	1400	140
-	55.0	-	-	250M	B	100	80	125	810	600	650	530	420	355	112	1750	1060	1600	1750	1060	1600	140	

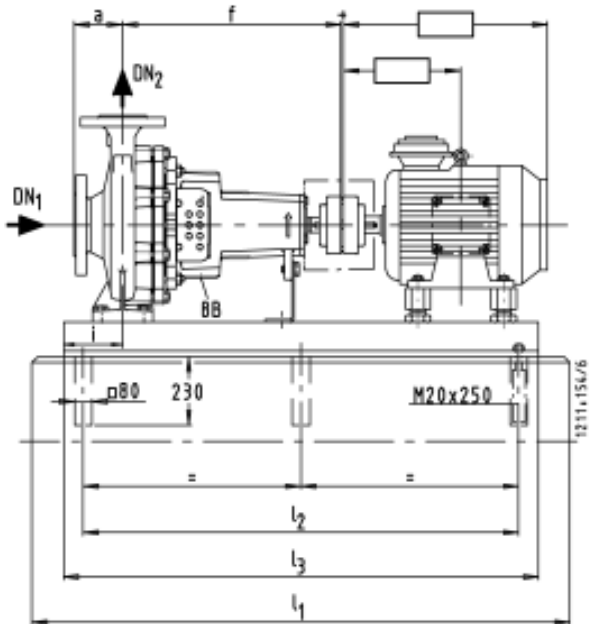
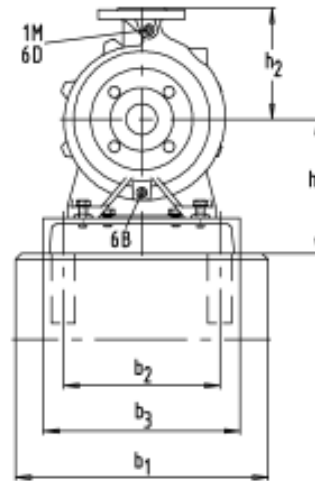
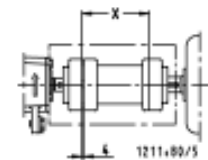
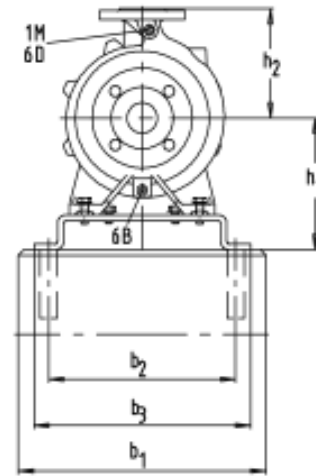
## Etanorm 100-160 - 100-250



Рис. А



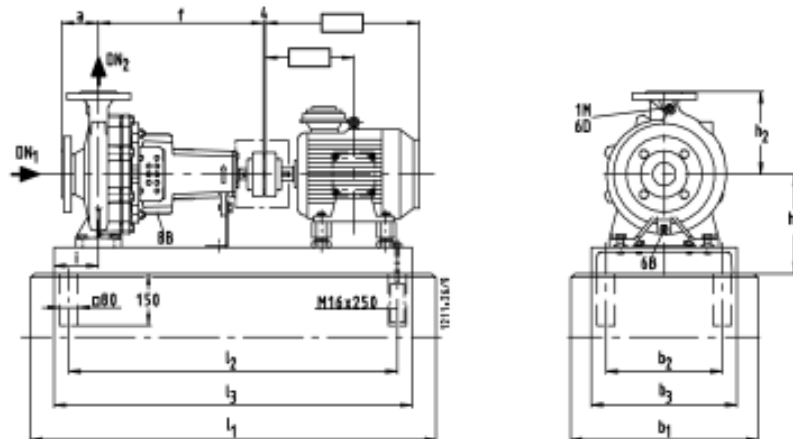

Рис. В

Размеры в мм

Etanorm	Двигатель об/мин				Типо- размер	Рису- нок														 			
	1450	1750	2900	3500			кВт	DN <sub>1</sub>	DN <sub>2</sub>	a	b <sub>1</sub>	b <sub>2</sub>	b <sub>3</sub>	f	h <sub>1</sub>	h <sub>2</sub>	i	l <sub>1</sub>	l <sub>2</sub>	l <sub>3</sub>	l <sub>1</sub>	l <sub>2</sub>	l <sub>3</sub>
100-160	3.0	-	-	-	100L	A	125	100	125	550	320	400	470	310	280	130	1150	940	1000	1400	1190	1250	140
	4.0	-	-	-	112M	A	125	100	125	550	320	400	470	310	280	130	1150	940	1000	1400	1190	1250	140
	-	5.5	-	-	132S	A	125	100	125	550	320	400	470	310	280	130	1150	940	1000	1400	1190	1250	140
	-	7.5	-	-	132M	A	125	100	125	550	320	400	470	310	280	130	1150	940	1000	1400	1190	1250	140
	-	-	22.0	-	180M	A	125	100	125	550	320	400	470	310	280	130	1400	1190	1250	1570	1360	1420	140
	-	-	30.0	-	200L	A	125	100	125	550	320	400	470	310	280	130	1400	1190	1250	1570	1360	1420	140
	-	-	37.0	-	200L	A	125	100	125	550	320	400	470	310	280	130	1400	1190	1250	1570	1360	1420	140
	-	-	45.0	-	225M	B	125	100	125	750	550	590	470	365	280	130	1550	940	1400	1550	940	1400	140
	-	-	55.0	-	250M	B	125	100	125	810	600	650	470	390	280	130	1750	1060	1600	1750	1060	1600	140
-	-	75.0	-	280S	B	125	100	125	880	670	720	470	420	280	130	1750	1060	1600	1750	1060	1600	140	
100-200	4.0	-	-	-	112M	A	125	100	125	550	320	400	470	310	280	130	1150	940	1000	1400	1190	1250	140
	5.5	-	-	-	132S	A	125	100	125	550	320	400	470	310	280	130	1150	940	1000	1400	1190	1250	140
	7.5	7.5	-	-	132M	A	125	100	125	550	320	400	470	310	280	130	1150	940	1000	1400	1190	1250	140
	-	11.0	-	-	160M	A	125	100	125	550	320	400	470	310	280	130	1400	1190	1250	1570	1360	1420	140
	-	15.0	-	-	160L	A	125	100	125	550	320	400	470	310	280	130	1400	1190	1250	1570	1360	1420	140
	-	-	30	-	200L	A	125	100	125	550	320	400	470	310	280	130	1400	1190	1250	1570	1360	1420	140
	-	-	37	-	200L	A	125	100	125	550	320	400	470	310	280	130	1400	1190	1250	1570	1360	1420	140
	-	-	45	-	225M	B	125	100	125	750	550	590	470	365	280	130	1550	940	1400	1550	940	1400	140
	-	-	55	-	250M	B	125	100	125	810	600	650	470	390	280	130	1750	1060	1600	1750	1060	1600	140
	-	-	75	75	280S	B	125	100	125	880	670	720	470	420	280	130	1750	1060	1600	1750	1060	1600	140
	-	-	90	-	280M	B	125	100	125	880	670	720	470	420	280	130	1750	1060	1600	1750	1060	1600	140
	-	-	110	-	315S	B	125	100	125	940	730	780	470	455	280	130	1800	1100	1650	1800	1100	1650	140
100-250	7.5	-	-	-	132M	A	125	100	140	550	320	400	470	335	280	130	1150	940	1000	1400	1190	1250	140
	11.0	11.0	-	-	160M	A	125	100	140	550	320	400	470	335	280	130	1400	1190	1250	1570	1360	1420	140
	15.0	15.0	-	-	160L	A	125	100	140	550	320	400	470	335	280	130	1400	1190	1250	1570	1360	1420	140
	-	18.5	-	-	180M	A	125	100	140	550	320	400	470	335	280	130	1400	1190	1250	1570	1360	1420	140
	-	22.0	-	-	180L	A	125	100	140	550	320	400	470	335	280	130	1400	1190	1250	1570	1360	1420	140
	-	-	55	-	250M	B	125	100	140	810	600	650	470	390	280	130	1750	1060	1600	1750	1060	1600	140
	-	-	75	-	280S	B	125	100	140	880	670	720	470	420	280	130	1750	1060	1600	1750	1060	1600	140
	-	-	90	-	280M	B	125	100	140	880	670	720	470	420	280	130	1750	1060	1600	1750	1060	1600	140
	-	-	110	-	315S	B	125	100	140	940	730	780	470	455	280	130	1800	1100	1650	1800	1100	1650	140

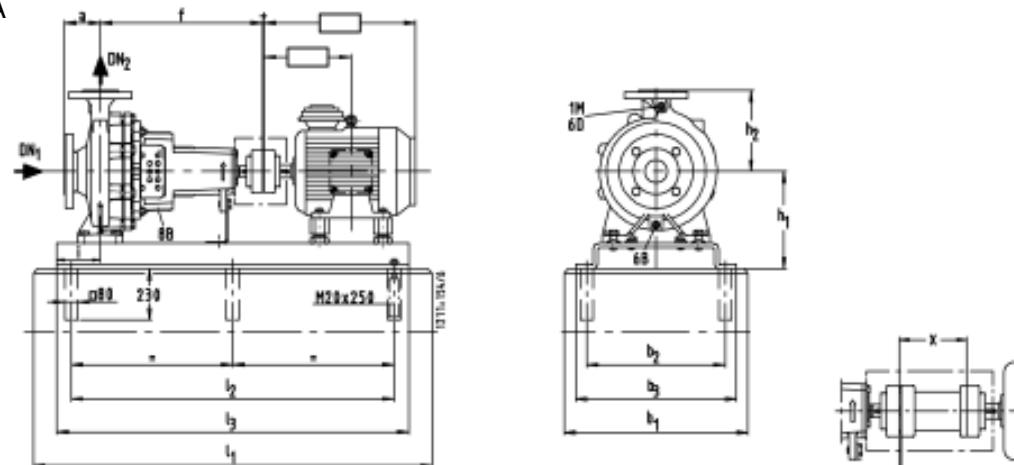

Etanorm 100-315 - 100-400



Рис. А



Рис. В

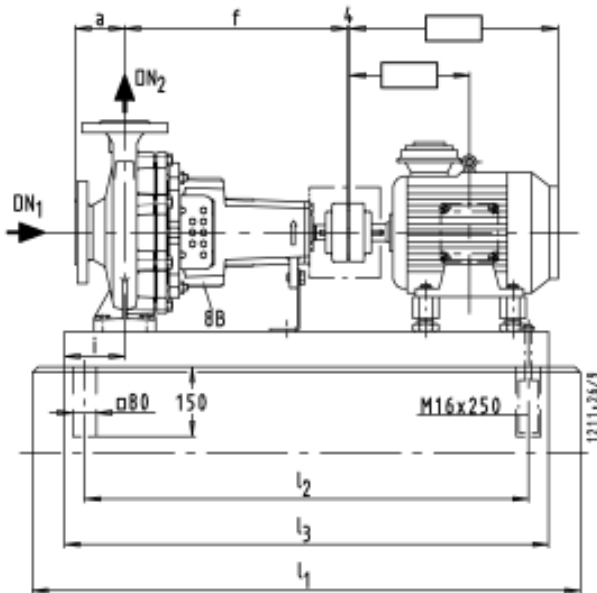

Размеры в мм

Etanorm	Двигатель об/мин				Типо- размер	Рису- нок	Размеры в мм																
	1450	1750	2900	3500			DN <sub>1</sub>	DN <sub>2</sub>	a	b <sub>1</sub>	b <sub>2</sub>	b <sub>3</sub>	f	h <sub>1</sub>	h <sub>2</sub>	i	l <sub>1</sub>	l <sub>2</sub>	l <sub>3</sub>	l <sub>1</sub>	l <sub>2</sub>	l <sub>3</sub>	x
100-315	15.0	-	-	-	160L	A	125	100	140	550	320	400	470	360	315	130	1400	1190	1250	1570	1360	1420	140
	18.5	-	-	-	180M	A	125	100	140	550	320	400	470	360	315	130	1400	1190	1250	1570	1360	1420	140
	22.0	-	-	-	180L	A	125	100	140	550	320	400	470	360	315	130	1400	1190	1250	1570	1360	1420	140
	30.0	30.0	-	-	200L	B	125	100	140	750	550	590	470	390	315	130	1550	940	1400	1550	940	1400	140
	-	37.0	-	-	225S	B	125	100	140	750	550	590	470	390	315	130	1550	940	1400	1550	940	1400	140
100-400	-	45.0	-	-	225M	B	125	100	140	750	550	590	470	390	315	130	1550	940	1400	1550	940	1400	140
	22.0	-	-	-	180L	B	125	100	140	810	600	650	530	420	355	112	1750	1060	1600	1750	1060	1600	140
	30.0	-	-	-	200L	B	125	100	140	810	600	650	530	420	355	112	1750	1060	1600	1750	1060	1600	140
	37.0	37.0	-	-	225S	B	125	100	140	810	600	650	530	420	355	112	1750	1060	1600	1750	1060	1600	140
	-	45.0	-	-	225M	B	125	100	140	810	600	650	530	420	355	112	1750	1060	1600	1750	1060	1600	140
100-400	-	55.0	-	-	250M	B	125	100	140	810	600	650	530	420	355	112	1750	1060	1600	1750	1060	1600	140
	-	75.0	-	-	280S	B	125	100	140	880	670	720	530	420	355	112	1750	1060	1600	1750	1060	1600	140

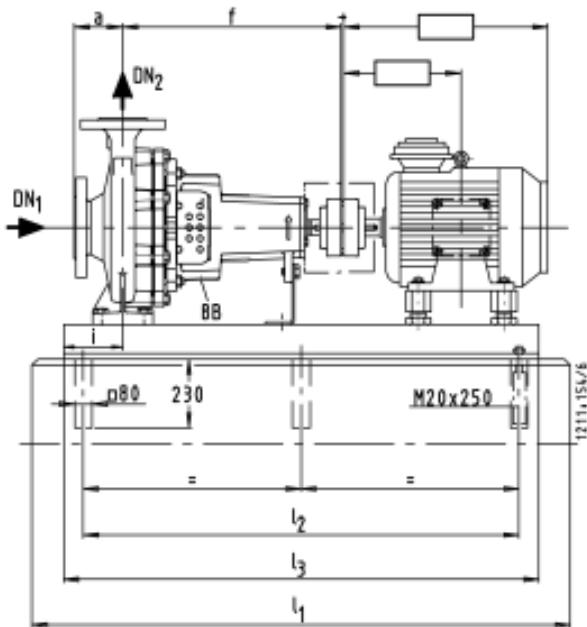
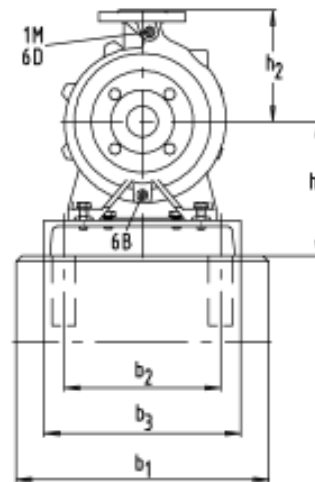
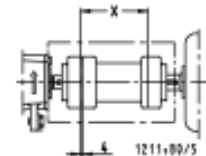
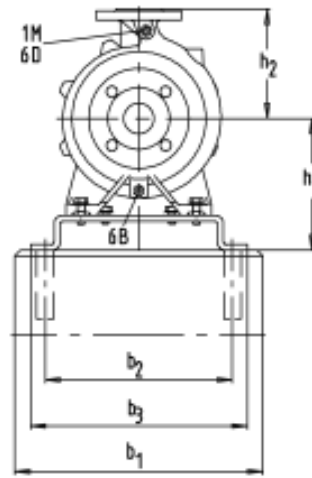
## Etanorm 125-200 - 125-400



Рис. А



Рис. В

Размеры в мм

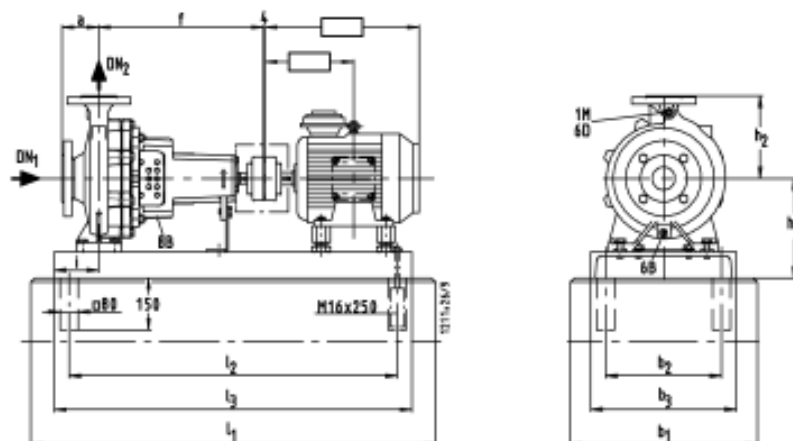
Etanorm	Двигатель об/мин   1450   1750   2900   3500				Рису- нок																		
	кВт					Типо- размер	DN <sub>1</sub>	DN <sub>2</sub>	a	b <sub>1</sub>	b <sub>2</sub>	b <sub>3</sub>	f	h <sub>1</sub>	h <sub>2</sub>	i	l <sub>1</sub>	l <sub>2</sub>	l <sub>3</sub>	l <sub>1</sub>	l <sub>2</sub>	l <sub>3</sub>	x
125-200	7.5	-	-	-	132M	A	150	125	140	550	320	400	470	360	315	130	1150	940	1000	1400	1190	1250	140
	11.0	-	-	-	160M	A	150	125	140	550	320	400	470	360	315	130	1400	1190	1250	1570	1360	1420	140
	15.0	15.0	-	-	160L	A	150	125	140	550	320	400	470	360	315	130	1400	1190	1250	1570	1360	1420	140
	-	18.5	-	-	180M	A	150	125	140	550	320	400	470	360	315	130	1400	1190	1250	1570	1360	1420	140
	-	22.0	-	-	180L	A	150	125	140	550	320	400	470	360	315	130	1400	1190	1250	1570	1360	1420	140
	-	-	55	-	250M	B	150	125	140	810	600	650	470	390	315	130	1750	1060	1600	1750	1060	1600	140
	-	-	75	-	280S	B	150	125	140	880	670	720	470	420	315	130	1750	1060	1600	1750	1060	1600	140
	-	-	90	90	280M	B	150	125	140	880	670	720	470	420	315	130	1750	1060	1600	1750	1060	1600	140
125-250	-	-	110	110	315S	B	150	125	140	940	730	780	470	455	315	130	1800	1100	1650	1800	1100	1650	140
	11.0	-	-	-	160M	A	150	125	140	550	320	400	470	360	355	130	1400	1190	1250	1570	1360	1420	140
	15.0	-	-	-	160L	A	150	125	140	550	320	400	470	360	355	130	1400	1190	1250	1570	1360	1420	140
	18.5	18.5	-	-	180M	A	150	125	140	550	320	400	470	360	355	130	1400	1190	1250	1570	1360	1420	140
	-	22	-	-	180L	A	150	125	140	550	320	400	470	360	355	130	1400	1190	1250	1570	1360	1420	140
	-	30	-	-	200L	B	150	125	140	750	550	590	470	390	355	130	1550	940	1400	1550	940	1400	140
	-	37	-	-	225S	B	150	125	140	750	550	590	470	390	355	130	1550	940	1400	1550	940	1400	140
	125-315	18.5	-	-	-	180M	B	150	125	140	810	600	650	530	420	355	112	1750	1060	1600	1750	1060	1600
22		-	-	-	180L	B	150	125	140	810	600	650	530	420	355	112	1750	1060	1600	1750	1060	1600	140
30		-	-	-	200L	B	150	125	140	810	600	650	530	420	355	112	1750	1060	1600	1750	1060	1600	140
37		37	-	-	225S	B	150	125	140	810	600	650	530	420	355	112	1750	1060	1600	1750	1060	1600	140
-		45	-	-	225M	B	150	125	140	810	600	650	530	420	355	112	1750	1060	1600	1750	1060	1600	140
-		55	-	-	250M	B	150	125	140	810	600	650	530	420	355	112	1750	1060	1600	1750	1060	1600	140
-		75	-	-	280S	B	150	125	140	880	670	720	530	420	355	112	1750	1060	1600	1750	1060	1600	140
125-400		30	-	-	-	200L	B	150	125	140	810	600	650	530	455	400	112	1750	1060	1600	1750	1060	1600
	37	-	-	-	225S	B	150	125	140	810	600	650	530	455	400	112	1750	1060	1600	1750	1060	1600	140
	45	-	-	-	225M	B	150	125	140	810	600	650	530	455	400	112	1750	1060	1600	1750	1060	1600	140
	55	55	-	-	250M	B	150	125	140	810	600	650	530	455	400	112	1750	1060	1600	1750	1060	1600	140
	75	75	-	-	280S	B	150	125	140	880	670	720	530	455	400	112	1750	1060	1600	1750	1060	1600	140
	-	90	-	-	280M	B	150	125	140	880	670	720	530	455	400	112	1750	1060	1600	1750	1060	1600	140
	-	110	-	-	315S	B	150	125	140	940	730	780	530	455	400	112	1800	1100	1650	1800	1100	1650	140

Etanorm 150-200 - 150-400

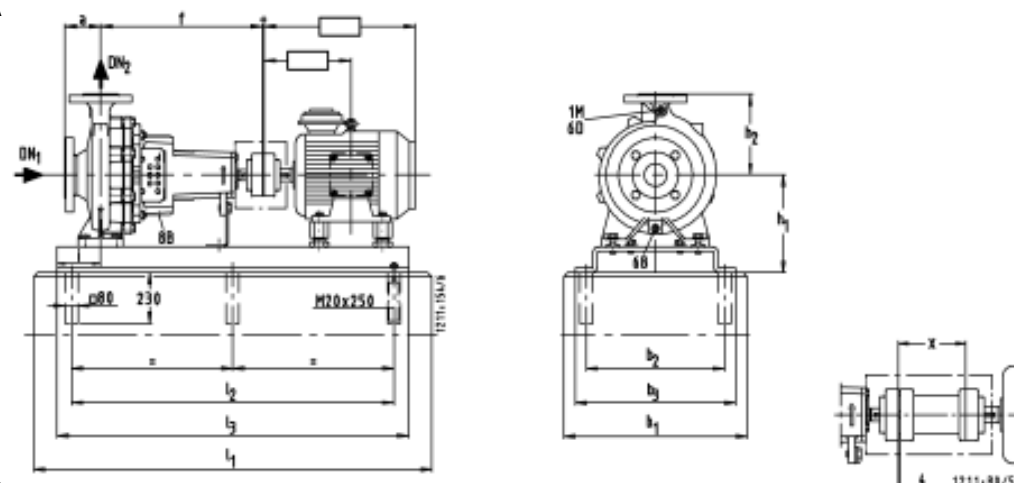
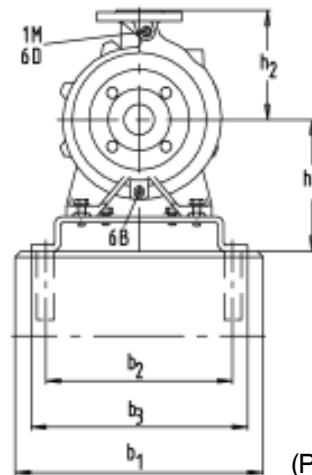
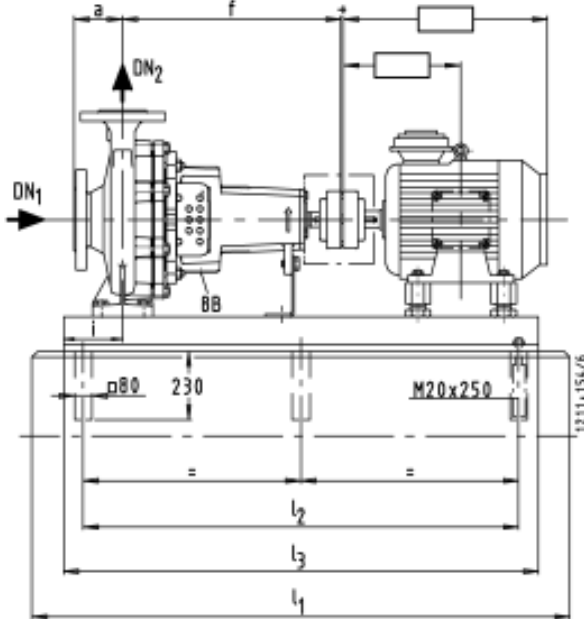

(Рис. В)

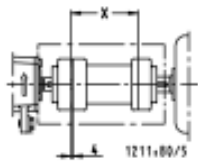

Размеры в мм

Etanorm	Двигатель об/мин				Типо- размер	Рису- нок																	
	1450	1750	2900	3500			кВт	DN <sub>1</sub>	DN <sub>2</sub>	a	b <sub>1</sub>	b <sub>2</sub>	b <sub>3</sub>	f	h <sub>1</sub>	h <sub>2</sub>	i	l <sub>1</sub>	l <sub>2</sub>	l <sub>3</sub>	l <sub>1</sub>	l <sub>2</sub>	l <sub>3</sub>
150-200	11.0	-	-	-	160M	B	200	150	160	880	670	720	470	420	400	112	1750	1060	1600	1750	1060	1600	140
	15.0	15.0	-	-	160L	B	200	150	160	880	670	720	470	420	400	112	1750	1060	1600	1750	1060	1600	140
	-	18.5	-	-	180M	B	200	150	160	880	670	720	470	420	400	112	1750	1060	1600	1750	1060	1600	140
	-	22.0	-	-	180L	B	200	150	160	880	670	720	470	420	400	112	1750	1060	1600	1750	1060	1600	140
150-250	15.0	-	-	-	160L	B	200	150	160	810	600	650	470	420	400	112	1750	1060	1600	1750	1060	1600	140
	18.5	-	-	-	180M	B	200	150	160	810	600	650	470	420	400	112	1750	1060	1600	1750	1060	1600	140
	22.0	-	-	-	180L	B	200	150	160	810	600	650	470	420	400	112	1750	1060	1600	1750	1060	1600	140
	30.0	30.0	-	-	200L	B	200	150	160	810	600	650	470	420	400	112	1750	1060	1600	1750	1060	1600	140
	-	37.0	-	-	225S	B	200	150	160	810	600	650	470	420	400	112	1750	1060	1600	1750	1060	1600	140
	-	45.0	-	-	225M	B	200	150	160	810	600	650	470	420	400	112	1750	1060	1600	1750	1060	1600	140
150-315	-	55.0	-	-	250M	B	200	150	160	810	600	650	470	420	400	112	1750	1060	1600	1750	1060	1600	140
	22	-	-	-	180L	B	200	150	160	880	670	720	530	420	400	112	1750	1060	1600	1750	1060	1600	140
	30	-	-	-	200L	B	200	150	160	880	670	720	530	420	400	112	1750	1060	1600	1750	1060	1600	140
	37	37	-	-	225S	B	200	150	160	880	670	720	530	420	400	112	1750	1060	1600	1750	1060	1600	140
	45	45	-	-	225M	B	200	150	160	880	670	720	530	420	400	112	1750	1060	1600	1750	1060	1600	140
	-	55	-	-	250M	B	200	150	160	880	670	720	530	420	400	112	1750	1060	1600	1750	1060	1600	140
150-400	-	75	-	-	280S	B	200	150	160	880	670	720	530	420	400	112	1750	1060	1600	1750	1060	1600	140
	-	90	-	-	280M	B	200	150	160	880	670	720	530	420	400	112	1750	1060	1600	1750	1060	1600	140
	37	-	-	-	225S	B	200	150	160	880	670	720	530	455	450	112	1750	1060	1600	1750	1060	1600	140
	45	-	-	-	225M	B	200	150	160	880	670	720	530	455	450	112	1750	1060	1600	1750	1060	1600	140
	55	-	-	-	250M	B	200	150	160	880	670	720	530	455	450	112	1750	1060	1600	1750	1060	1600	140
	75	75	-	-	280S	B	200	150	160	880	670	720	530	455	450	112	1750	1060	1600	1750	1060	1600	140
90	90	-	-	280M	B	200	150	160	880	670	720	530	455	450	112	1750	1060	1600	1750	1060	1600	140	
-	110	-	-	315S	B	200	150	160	940	730	780	530	455	450	112	1800	1100	1650	1800	1100	1650	140	

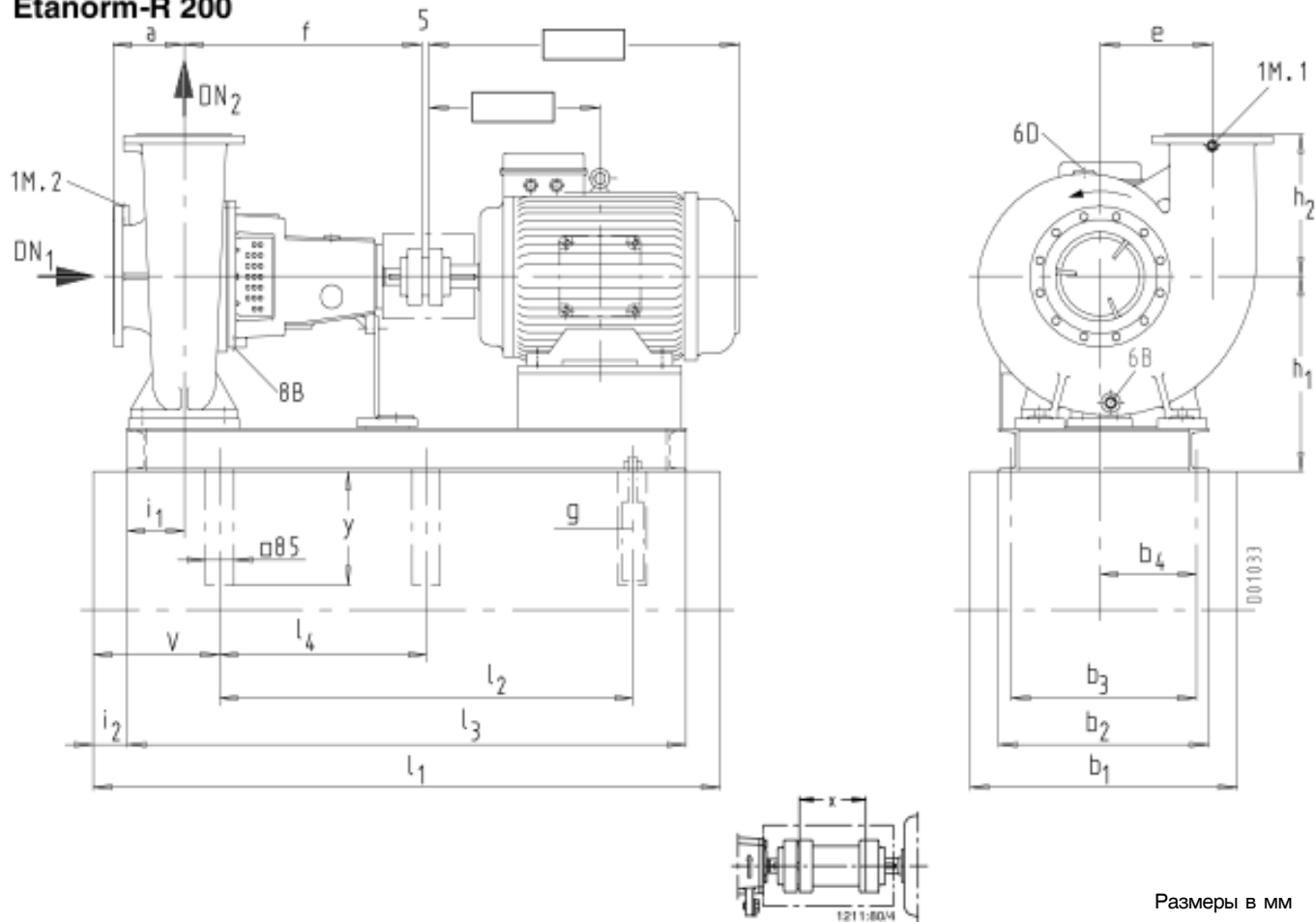
**Etanorm-R 200**

Размеры в мм

Etanorm-R	⊕ IP 55 960 1450 116 1750 0 об/мин кВт	Типо- раз- мер																																
			1) DN <sub>1</sub>	1) DN <sub>2</sub>	a	e	f	g	h <sub>2</sub>	i <sub>1</sub>	y	b <sub>1</sub>	b <sub>2</sub>	b <sub>3</sub>	b <sub>4</sub>	h <sub>1</sub>	l <sub>2</sub>	l <sub>1</sub>	l <sub>2</sub>	l <sub>3</sub>	v	b <sub>1</sub>	b <sub>2</sub>	b <sub>3</sub>	b <sub>4</sub>	h <sub>1</sub>	l <sub>2</sub>	l <sub>1</sub>	l <sub>2</sub>	l <sub>3</sub>	l <sub>4</sub>	v	x	
200-250	4.0	--	132M	200	200	220	250	815	M20x400	345	170	450	820	570	525	293	505	115	1920	1150	1695	285	900	650	605	333	505	110	2000	1250	1780	280	200	
200-250	5.5	--	132M	200	200	220	250	815	M20x400	345	170	450	820	570	525	293	505	115	1920	1150	1695	285	900	650	605	333	505	110	2000	1250	1780	280	200	
200-250	7.5	--	160M	200	200	220	250	815	M20x400	345	170	450	820	570	525	293	505	115	1920	1150	1695	285	1010	760	710	385	525	110	2100	1300	1880	330	200	
200-250	11.0	15.0	160L	200	200	220	250	815	M20x400	345	170	450	820	570	525	293	505	115	1920	1150	1695	285	1010	760	710	385	525	110	2100	1300	1880	330	200	
200-250	--	18.5	180M	200	200	220	250	815	M20x400	345	170	450	820	570	525	293	505	115	1920	1150	1695	285	1010	760	710	385	525	110	2100	1300	1880	330	200	
200-250	15.0	22.0	180L	200	200	220	250	815	M20x400	345	170	450	820	570	525	293	505	115	1920	1150	1695	285	1010	760	710	385	525	110	2100	1300	1880	330	200	
200-250	--	30.0	200L	200	200	220	250	815	M20x400	345	170	450	900	660	605	333	505	110	2000	1250	1780	280	1110	860	810	435	545	110	2260	1450	2040	330	200	
200-250	--	37.0	225S	200	200	220	250	815	M20x400	345	170	450	900	660	605	333	505	110	2000	1250	1780	280	1110	860	810	435	545	110	2260	1450	2040	330	200	
200-250	--	45.0	225M	200	200	220	250	815	M20x400	345	170	450	900	660	605	333	505	110	2000	1250	1780	280	1110	860	810	435	545	110	2260	1450	2040	330	200	
200-260	7.5	--	160M	200	200	200	300	715	M20x400	350	170	450	820	570	525	293	505	115	1920	1150	1695	285	900	650	605	333	550	110	2000	1250	1780	280	200	
200-260	11.0	18.5	160L	200	200	200	300	715	M20x400	350	170	450	820	570	525	293	505	115	1920	1150	1695	285	900	650	605	333	550	110	2000	1250	1780	280	200	
200-260	15.0	22.0	180L	200	200	200	300	715	M20x400	350	170	450	820	570	525	293	505	115	1920	1150	1695	285	900	650	605	333	550	110	2000	1250	1780	280	200	
200-260	15.0	22.0	180L	200	200	200	300	715	M20x400	350	170	450	820	570	525	293	505	115	1920	1150	1695	285	900	650	605	333	550	110	2000	1250	1780	280	200	
200-260	18.5	30.0	200L	200	200	200	300	715	M20x400	350	170	450	820	570	525	293	505	115	1920	1150	1695	285	1010	760	710	385	570	110	2100	1300	1880	330	200	
200-260	--	37.0	225S	200	200	200	300	715	M20x400	350	170	450	820	570	525	293	505	115	1920	1150	1695	285	1010	760	710	385	570	110	2100	1300	1880	330	200	
200-260	--	45.0	225M	200	200	200	300	715	M20x400	350	170	450	820	570	525	293	505	115	1920	1150	1695	285	1010	760	710	385	570	110	2100	1300	1880	330	200	
200-260	--	55.0	250M	200	200	200	300	715	M20x400	350	170	450	900	660	605	333	505	110	2000	1250	1780	280	1110	860	810	435	590	110	2260	1450	2040	330	200	
200-330	11.0	--	160L	250	200	200	315	715	M20x400	400	170	450	820	570	525	293	505	115	1920	1150	1695	285	900	650	605	333	550	110	2000	1250	1780	280	200	
200-330	15.0	18.5	180M	250	200	200	315	715	M20x400	400	170	450	820	570	525	293	505	115	1920	1150	1695	285	900	650	605	333	550	110	2000	1250	1780	280	200	
200-330	15.0	22.0	180L	250	200	200	315	715	M20x400	400	170	450	820	570	525	293	505	115	1920	1150	1695	285	900	650	605	333	550	110	2000	1250	1780	280	200	
200-330	18.5	--	200L	250	200	200	315	715	M20x400	400	170	450	820	570	525	293	505	115	1920	1150	1695	285	1010	760	710	385	570	110	2100	1300	1880	330	200	
200-330	22.0	30.0	200L	250	200	200	315	715	M20x400	400	170	450	820	570	525	293	505	115	1920	1150	1695	285	1010	760	710	385	570	110	2100	1300	1880	330	200	
200-330	--	37.0	225S	250	200	200	315	715	M20x400	400	170	450	820	570	525	293	505	115	1920	1150	1695	285	1010	760	710	385	570	110	2100	1300	1880	330	200	
200-330	30.0	45.0	225M	250	200	200	315	715	M20x400	400	170	450	820	570	525	293	505	115	1920	1150	1695	285	1010	760	710	385	570	110	2100	1300	1880	330	200	
200-330	--	55.0	250M	250	200	200	315	715	M20x400	400	170	450	900	660	605	333	505	110	2000	1250	1780	280	1110	860	810	435	590	110	2260	1450	2040	330	200	
200-330	--	75.0	280S	250	200	200	315	715	M20x400	400	170	450	900	660	605	333	505	110	2000	1250	1780	280	1110	860	810	435	590	110	2260	1450	2040	330	200	
200-330	--	90.0	280M	250	200	200	315	715	M20x400	400	170	450	1010	760	710	385	570	110	2100	1300	1880	330	1110	860	810	435	590	110	2260	1450	2040	330	200	
200-330	--	110.0	315S	250	200	200	315	715	M20x400	400	170	450	1010	760	710	385	570	110	2100	1300	1880	330	1110	860	800	430	610	110	2450	1650	2230	825	330	200
200-400	18.5	--	200L	250	200	180	290	715	M20x400	400	170	450	820	570	525	293	505	115	1920	1150	1695	285	1010	760	710	385	570	110	2100	1300	1880	330	200	
200-400	22.0	--	200L	250	200	180	290	715	M20x400	400	170	450	820	570	525	293	505	115	1920	1150	1695	285	1010	760	710	385	570	110	2100	1300	1880	330	200	
200-400	30.0	--	225M	250	200	180	290	715	M20x400	400	170	450	820	570	525	293	505	115	1920	1150	1695	285	1010	760	710	385	570	110	2100	1300	1880	330	200	
200-400	37.0	--	250M	250	200	180	290	715	M20x400	400	170	450	900	660	605	333	505	110	2000	1250	1780	280	1110	860	810	435	590	110	2260	1450	2040	330	200	
200-400	45.0	75.0	280S	250	200	180	290	715	M20x400	400	170	450	900	660	605	333	505	110	2000	1250	1780	280	1110	860	810	435	590	110	2260	1450	2040	330	200	
200-400	55.0	90.0	280M	250	200	180	290	715	M20x400	400	170	450	1010	760	710	385	570	110	2100	1300	1880	330	1110	860	810	435	590	110	2260	1450	2040	330	200	
200-400	75.0	110.0	315S	250	200	180	290	715	M20x400	400	170	450	1010	760	710	385	570	110	2100	1300	1880	330	1110	860	800	430	610	110	2450	1650	2230	825	330	200
200-400	--	132.0	315M	250	200	180	290	715	M20x400	400	170	450	1110	860	810	435	590	110	2260	1450	2040	330	1110	860	800	430	610	110	2450	1650	2230	825	330	200
200-500	30.0	--	225M	250	200	200	387	715	M20x400	450	195	450	1010	760	710	385	670	110	2000	1200	1780	330	1010	760	710	385	670	110	2100	1300	1880	330	200	
200-500	37.0	--	250M	250	200	200	387	715	M20x400	450	195	450	1010	760	710	385	670	110	2000	1200	1780	330	1110	860	810	435	690	110	2260	1450	2040	330	200	
200-500	45.0	--	280S	250	200	200	387	715	M20x400	450	195	450	1010	760	710	385	670	110	2100	1300	1880	330	1110	860	810	435	690	110	2260	1450	2040	330	200	
200-500	55.0	--	280M	250	200	200	387	715	M20x400	450	195	450	1010	760	710	385	670																	

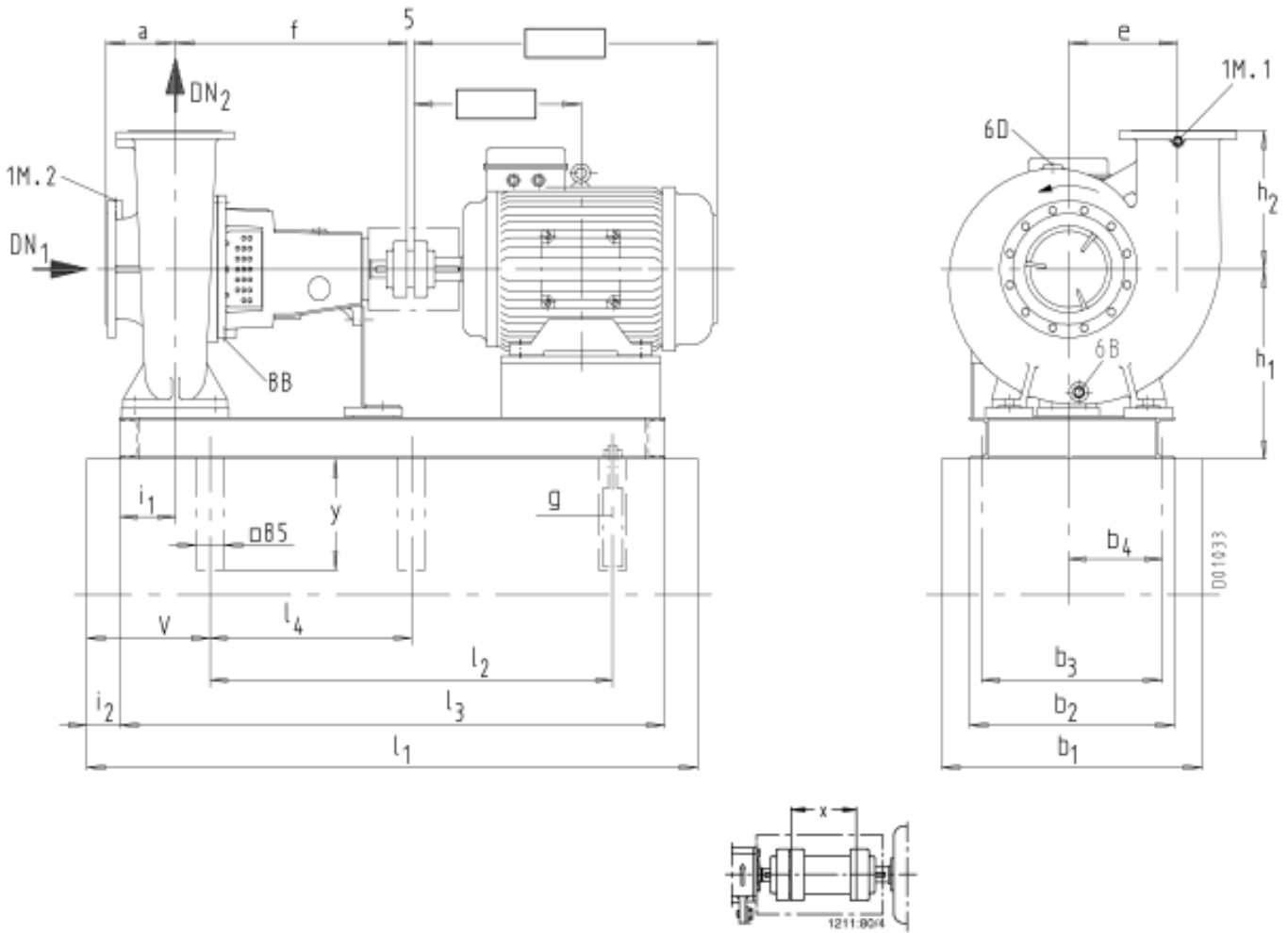
**Etanorm-R 250**

Размеры в мм

Etanorm-R	IP 55 960 1450 116 1750 0 об/мин кВт	Типоразмер	Side View Dimensions																	Front View Dimensions														
			1) DN <sub>1</sub>	1) DN <sub>2</sub>	a	ø	f	g	h <sub>2</sub>	i <sub>1</sub>	y	b <sub>5</sub>	b <sub>2</sub>	b <sub>3</sub>	b <sub>4</sub>	h <sub>1</sub>	l <sub>2</sub>	l <sub>1</sub>	l <sub>2</sub>	l <sub>3</sub>	v	b <sub>1</sub>	b <sub>2</sub>	b <sub>3</sub>	b <sub>4</sub>	h <sub>1</sub>	l <sub>2</sub>	l <sub>1</sub>	l <sub>2</sub>	l <sub>3</sub>	l <sub>4</sub>	v	x	
250-300	11.0	--	180L	250	250	225	300	830	M20x400	400	170	450	1010	760	710	385	570	115	1920	1150	1695	310	1010	760	710	385	570	110	2100	1300	1880	330	250	
250-300	--	18.5	180M	250	250	225	300	830	M20x400	400	170	450	1010	760	710	385	570	115	1920	1150	1695	310	1010	760	710	385	570	110	2100	1300	1880	330	250	
250-300	15.0	--	190L	250	250	225	300	830	M20x400	400	170	450	1010	760	710	385	570	115	1920	1150	1695	310	1110	860	810	445	590	110	2260	1450	2040	330	250	
250-300	18.5	30.0	202L	250	250	225	300	830	M20x400	400	170	450	1010	760	710	385	570	110	2000	1200	1780	330	1110	860	810	445	590	110	2260	1450	2040	330	250	
250-300	22.0	--	202L	250	250	225	300	830	M20x400	400	170	450	1010	760	710	385	570	110	2000	1200	1780	330	1110	860	810	445	590	110	2260	1450	2040	330	250	
250-300	--	37.0	225S	250	250	225	300	830	M20x400	400	170	450	1010	760	710	385	570	110	2000	1200	1780	330	1110	860	810	445	590	110	2260	1450	2040	330	250	
250-300	30.0	45.0	225M	250	250	225	300	830	M20x400	400	170	450	1010	760	710	385	570	110	2000	1200	1780	330	1110	860	810	445	590	110	2260	1450	2040	330	250	
250-300	--	55.0	250M	250	250	225	300	830	M20x400	400	170	450	1010	760	710	385	570	110	2100	1300	1880	330	1110	860	800	430	610	110	2450	1650	2230	825	330	250
250-300	--	75.0	280S	250	250	225	300	830	M20x400	400	170	450	1010	760	710	385	570	110	2100	1300	1880	330	1110	860	800	430	610	110	2450	1650	2230	825	330	250
250-300	--	90.0	280M	250	250	225	300	830	M20x400	400	170	450	1110	860	810	435	590	110	2260	1450	2040	330	1110	860	800	430	610	110	2450	1650	2230	825	330	250
250-330	15.0	--	190L	250	250	250	345	715	M20x400	400	195	450	1010	760	710	395	620	115	1920	1150	1695	310	1010	760	710	395	620	110	2100	1300	1880	330	200	
250-330	18.5	--	202L	250	250	250	345	715	M20x400	400	195	450	1010	760	710	395	620	115	1920	1150	1695	310	1010	760	710	395	620	110	2100	1300	1880	330	200	
250-330	22.0	--	202L	250	250	250	345	715	M20x400	400	195	450	1010	760	710	395	620	115	1920	1150	1695	310	1010	760	710	395	620	110	2100	1300	1880	330	200	
250-330	37.0	--	225S	250	250	250	345	715	M20x400	400	195	450	1010	760	710	395	620	110	2000	1200	1780	330	1010	760	710	395	620	110	2100	1300	1880	330	200	
250-330	30.0	--	225M	250	250	250	345	715	M20x400	400	195	450	1010	760	710	395	620	110	2000	1200	1780	330	1010	760	710	395	620	110	2100	1300	1880	330	200	
250-330	37.0	55.0	250M	250	250	250	345	715	M20x400	400	195	450	1010	760	710	395	620	110	2000	1200	1780	330	1110	860	810	445	640	110	2240	1450	2040	330	200	
250-330	45.0	75.0	280S	250	250	250	345	715	M20x400	400	195	450	1010	760	710	395	620	110	2100	1300	1880	330	1110	860	810	445	640	110	2240	1450	2040	330	200	
250-330	--	90.0	280M	250	250	250	345	715	M20x400	400	195	450	1010	760	710	395	620	110	2100	1300	1880	330	1110	860	810	445	640	110	2240	1450	2040	330	200	
250-330	--	110.0	315S	250	250	250	345	715	M20x400	400	195	450	1110	860	810	445	640	110	2260	1450	2040	330	1110	860	800	440	660	110	2450	1650	2230	825	330	200
250-330	--	132.0	315M	250	250	250	345	715	M20x400	400	195	450	1110	860	810	445	640	110	2260	1450	2040	330	1110	860	800	440	660	110	2450	1650	2230	825	330	200
250-400	18.5	--	202L	300	250	180	335	715	M20x400	480	195	450	1010	760	710	385	620	115	1920	1150	1695	310	1010	760	710	385	620	110	2100	1300	1880	330	200	
250-400	22.0	--	202L	300	250	180	335	715	M20x400	480	195	450	1010	760	710	385	620	115	1920	1150	1695	310	1010	760	710	385	620	110	2100	1300	1880	330	200	
250-400	37.0	--	225S	300	250	180	335	715	M20x400	480	195	450	1010	760	710	385	620	110	2000	1200	1780	330	1010	760	710	385	620	110	2100	1300	1880	330	200	
250-400	30.0	--	225M	300	250	180	335	715	M20x400	480	195	450	1010	760	710	385	620	110	2000	1200	1780	330	1010	760	710	385	620	110	2100	1300	1880	330	200	
250-400	37.0	--	250M	300	250	180	335	715	M20x400	480	195	450	1010	760	710	385	620	110	2000	1200	1780	330	1110	860	810	435	640	110	2260	1450	2040	330	200	
250-400	45.0	--	280S	300	250	180	335	715	M20x400	480	195	450	1010	760	710	385	620	110	2100	1300	1880	330	1110	860	810	435	640	110	2260	1450	2040	330	200	
250-400	--	75.0	280M	300	250	180	335	715	M20x400	480	195	450	1010	760	710	385	620	110	2100	1300	1880	330	1110	860	810	435	640	110	2260	1450	2040	330	200	
250-400	55.0	90.0	280M	300	250	180	335	715	M20x400	480	195	450	1010	760	710	385	620	110	2100	1300	1880	330	1110	860	810	435	640	110	2260	1450	2040	330	200	
250-400	75.0	110.0	315S	300	250	180	335	715	M20x400	480	195	450	1110	860	810	435	640	110	2260	1450	2040	330	1110	860	800	430	660	110	2450	1650	2230	825	330	200
250-400	--	132.0	315M	300	250	180	335	715	M20x400	480	195	450	1110	860	810	435	640	110	2260	1450	2040	330	1110	860	800	430	660	110	2450	1650	2230	825	330	200
250-500	45.0	--	280S	300	250	225	425	715	M20x400	500	220	450	1110	860	810	445	690	110	2260	1450	2040	330	1110	860	810	445	690	110	2260	1450	2040	330	200	
250-500	55.0	--	280M	300	250	225	425	715	M20x400	500	220	450	1110	860	810	445	690	110	2260	1450	2040	330	1110	860	800	440	710	110	2450	1650	2230	825	330	200
250-500	75.0	--	315S	300	250	225	425	715	M20x400	500	220	450	1110	860	810	445	690	110	2260	1450	2040	330	1110	860	800	440	710	110	2450	1650	2230	825	330	200
250-500	90.0	--	315M	300	250	225	425	715	M20x400	500	220	450	1110	860	810	445	690	110	2260	1450	2040	330	1110	860	800	440	710	110	2450	1650	2230	825	330	200

 1) DN = EN 1092-2/DN...PN 10/21/GJL-250/B71C  
 DN = EN 1092-2/DN...PN 10/21/GJS 400-18-LT/B

## Etanorm-R 300

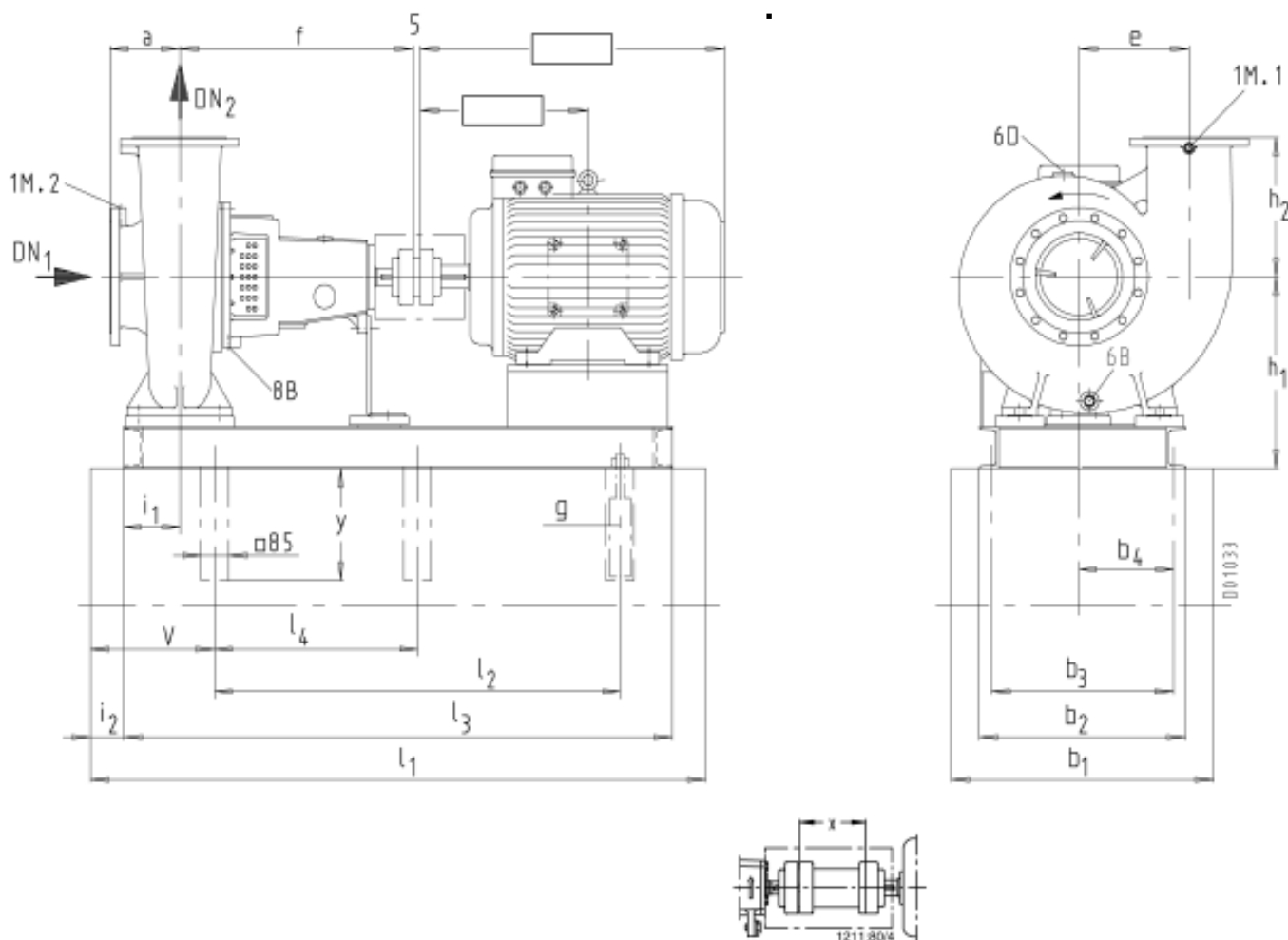

Размеры в мм

Etanorm-R	IP 55 900 1450 1180 1750 об/мин кВт	Типо- раз- мер																																		
			φ DN <sub>1</sub>	h DN <sub>2</sub>	a	e	f	g	h <sub>2</sub>	i <sub>1</sub>	y	b <sub>1</sub>	b <sub>2</sub>	b <sub>3</sub>	b <sub>4</sub>	h <sub>1</sub>	l <sub>2</sub>	l <sub>1</sub>	l <sub>2</sub>	l <sub>3</sub>	v	b <sub>1</sub>	b <sub>2</sub>	b <sub>3</sub>	b <sub>4</sub>	h <sub>1</sub>	h <sub>2</sub>	h <sub>1</sub>	l <sub>2</sub>	l <sub>1</sub>	l <sub>2</sub>	l <sub>3</sub>	l <sub>4</sub>	v	x	
300-340	15.0	-	180L	300	300	255	315	850	M20x400	450	195	450	1010	760	710	395	620	11	0	2000	1200	1780	330	1110	860	810	445	640	11	0	2260	1450	2040		330	250
300-340	18.5	-	200L	300	300	255	315	850	M20x400	450	195	450	1010	760	710	395	620	11	0	2000	1200	1780	330	1110	860	810	445	640	11	0	2260	1450	2040		330	250
300-340	22.0	-	200L	300	300	255	315	850	M20x400	450	195	450	1010	760	710	395	620	11	0	2000	1200	1780	330	1110	860	810	445	640	11	0	2260	1450	2040		330	250
300-340	-	37.0	225S	300	300	255	315	850	M20x400	450	195	450	1010	760	710	395	620	11	0	2000	1200	1780	330	1110	860	810	445	640	11	0	2260	1450	2040		330	250
300-340	30.0	45.0	225M	300	300	255	315	850	M20x400	450	195	450	1010	760	710	395	620	11	0	2000	1200	1780	330	1110	860	800	440	660	11	0	2450	1650	2230		330	250
300-340	30.0	55.0	250M	300	300	255	315	850	M20x400	450	195	450	1010	760	710	395	620	11	0	2000	1200	1780	330	1110	860	800	440	660	11	0	2450	1650	2230	825	330	250
300-340	37.0	-	250M	300	300	255	315	850	M20x400	450	195	450	1010	760	710	395	620	11	0	2100	1300	1880	330	1110	860	800	440	660	11	0	2450	1650	2230	825	330	250
300-340	45.0	75.0	280S	300	300	255	315	850	M20x400	450	195	450	1110	860	810	445	640	11	0	2260	1450	2040	330	1110	860	800	440	660	11	0	2450	1650	2230	825	330	250
300-340	-	90.0	280M	300	300	255	315	850	M20x400	450	195	450	1110	860	810	445	640	11	0	2260	1450	2040	330	1110	860	800	440	660	11	0	2450	1650	2230	825	330	250
300-340	-	110.0	315S	300	300	255	315	850	M20x400	450	195	450	1110	860	810	445	640	11	0	2260	1450	2040	330	1110	860	800	440	660	11	0	2590	1800	2370	900	330	250
300-340	-	132.0	315M	300	300	255	315	850	M20x400	450	195	450	1110	860	800	440	660	11	0	2450	1650	2230	330	1110	860	800	440	660	11	0	2590	1800	2370	900	330	250
300-360	30.0	-	225M	350	300	300	387	717	M20x400	450	220	450	1010	760	710	395	730	110	0	2000	1200	1780	330	1110	860	810	445	750	110	2260	1450	2040		330	250	
300-360	37.0	-	250M	350	300	300	387	717	M20x400	450	220	450	1010	760	710	395	730	110	0	2100	1300	1880	330	1110	860	810	445	750	110	2250	1450	2040		330	250	
300-360	45.0	-	280S	300	300	300	387	717	M20x400	450	220	450	1010	760	710	395	730	110	0	2100	1300	1880	330	1110	860	800	440	750	110	2450	1650	2230	825	330	250	
300-360	55.0	90.0	280M	350	300	300	387	717	M20x400	450	220	450	1010	760	710	395	730	110	0	2100	1300	1880	330	1110	860	800	440	750	110	2450	1650	2230	825	330	250	
300-360	75.0	110.0	315S	300	300	300	387	717	M20x400	450	220	450	1110	860	810	445	750	110	0	2260	1450	2040	330	1110	860	800	440	750	110	2450	1650	2230	825	330	250	
300-360	-	132.0	315M	300	300	300	387	717	M20x400	450	220	450	1110	860	810	445	750	110	0	2260	1450	2040	330	1110	860	800	440	750	110	2450	1650	2230	825	330	250	
300-400	37.0	-	250M	350	300	300	425	715	M20x400	500	220	450	1110	860	810	455	750	110	2260	1450	2040	330	1110	860	810	455	750	110	2260	1450	2040		330	250		
300-400	45.0	-	280S	350	300	300	425	715	M20x400	500	220	450	1110	860	810	455	750	110	2260	1450	2040	330	1110	860	800	450	770	110	2450	1650	2230	825	330	250		
300-400	55.0	-	280M	350	300	300	425	715	M20x400	500	220	450	1110	860	810	455	750	110	2260	1450	2040	330	1110	860	800	450	770	110	2450	1650	2230	825	330	250		
300-400	75.0	-	315S	350	300	300	425	715	M20x400	500	220	450	1110	860	810	455	750	110	2260	1450	2040	330	1110	860	800	450	770	110	2450	1650	2230	825	330	250		
300-400	-	110.0	315M	350	300	300	425	715	M20x400	500	220	450	1110	860	810	455	750	110	2260	1450	2040	330	1110	860	800	450	770	110	2450	1650	2230	825	330	250		
300-400	90.0	132.0	315M	350	300	300	425	715	M20x400	500	220	450	1110	860	810	455	750	110	2260	1450	2040	330	1110	860	800	450	770	110	2450	1650	2230	825	330	250		
300-500	75.0	-	315S	350	300	300	450	715	M20x400	500	220	450	1110	860	810	455	750	110	2260	1450	2040	330	1110	860	800	450	770	110	2450	1650	2230	825	330	250		
300-500	75.0	-	315M	350	300	300	450	715	M20x400	500	220	450	1110	860	810	455	750	110	2260	1450	2040	330	1110	860	800	450	770	110	2450	1650	2230	825	330	250		

 1) DN - EN 1092-2/DN...PN 10/21/GJL-250/B710  
 DN - EN 1092-2/DN...PN 16/21/GJS-400-18-LT/B

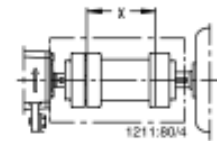
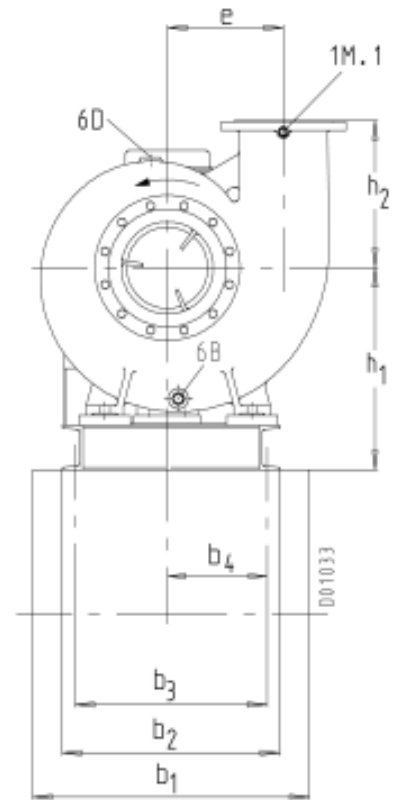
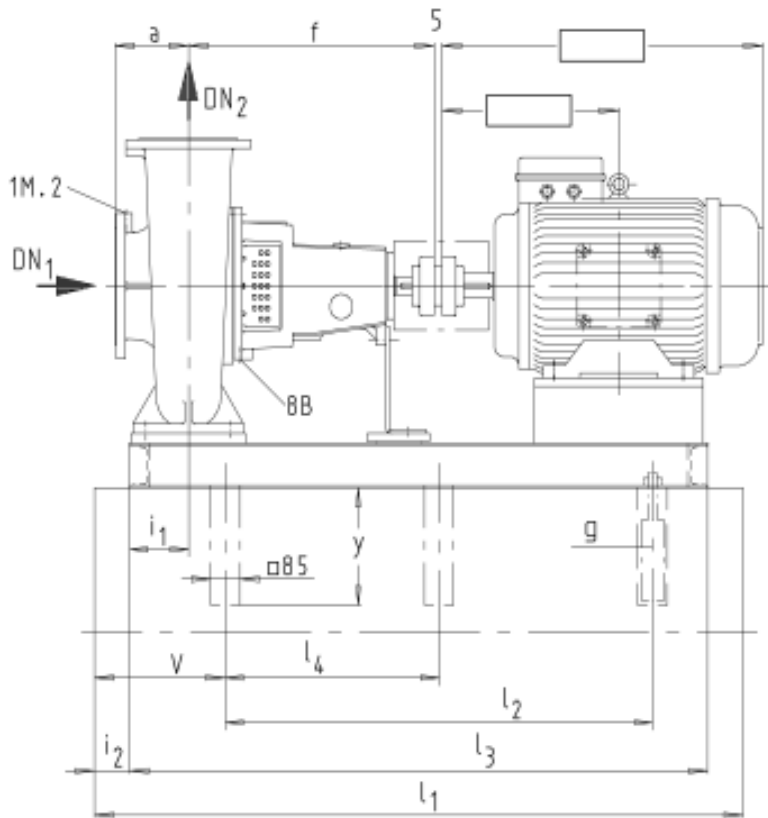
**Etanorm-R 125-500/2 - 150-500.1**

Размеры в мм

Etanorm-R	IP 55 960 1450 1160 1750	Тип-размер																																
			$n_1$ DN <sub>1</sub>	$n_2$ DN <sub>2</sub>	a	e	f	g	$h_2$	i	y	$b_1$	$b_2$	$b_3$	$b_4$	$h_1$	$l_2$	$l_1$	$l_2$	$l_3$	v	$b_1$	$b_2$	$b_3$	$b_4$	$h_1$	$l_2$	$l_1$	$l_2$	$l_3$	$l_4$	v	x	
125-500/2	11.0	-	160L	150	125	245	270	703	M20x400	300	145	450	1010	760	710	370	525	115	1920	1150	1695	310	1010	760	710	370	525	115	1920	1150	1695	310	310	200
125-500/2	18.5	-	180M	150	125	245	270	703	M20x400	300	145	450	1010	760	710	370	525	115	1920	1150	1695	310	1010	760	710	370	525	115	1920	1150	1695	310	310	200
125-500/2	15.0	-	180L	150	125	245	270	703	M20x400	300	145	450	1010	760	710	370	525	115	1920	1150	1695	310	900	650	605	318	505	110	2000	1250	1780	280	280	200
125-500/2	18.5	-	200L	150	125	245	270	703	M20x400	300	145	450	1010	760	710	370	525	115	1920	1150	1695	310	1010	760	710	370	525	110	2100	1300	1880	330	200	
125-500/2	22.0	-	200L	150	125	245	270	703	M20x400	300	145	450	1010	760	710	370	525	115	1920	1150	1695	310	1010	760	710	370	525	110	2100	1300	1880	330	200	
125-500/2	-	30.0	200L	150	125	245	270	703	M20x400	300	145	450	1010	760	710	370	525	115	1920	1150	1695	310	1010	760	710	370	525	110	2100	1300	1880	330	200	
125-500/2	-	37.0	225S	150	125	245	270	703	M20x400	300	145	450	1010	760	710	370	525	115	1920	1150	1695	310	1010	760	710	370	525	110	2100	1300	1880	330	200	
125-500/2	30.0	45.0	225M	150	125	245	270	703	M20x400	300	145	450	1010	760	710	370	525	115	1920	1150	1695	310	1010	760	710	370	525	110	2100	1300	1880	330	200	
125-500/2	37.0	55.0	250M	150	125	245	270	703	M20x400	300	145	450	1010	760	710	370	525	115	1920	1150	1695	310	1010	760	710	370	525	110	2100	1300	1880	330	200	
125-500/2	45.0	75.0	280S	150	125	245	270	703	M20x400	300	145	450	900	650	605	318	505	110	2000	1250	1780	280	1110	860	810	420	545	110	2260	1450	2040	330	200	
125-500/2	55.0	90.0	280M	150	125	245	270	703	M20x400	300	145	450	900	650	605	318	505	110	2000	1250	1780	280	1110	860	810	420	545	110	2260	1450	2040	330	200	
150-500.1	18.5	-	200L	200	150	190	315	715	M20x400	450	170	450	820	570	710	365	550	115	1920	1150	1695	285	1010	760	710	365	570	110	2100	1300	1880	330	200	
150-500.1	22.0	-	200L	200	150	190	315	715	M20x400	450	170	450	820	570	710	365	550	115	1920	1150	1695	285	1010	760	710	365	570	110	2100	1300	1880	330	200	
150-500.1	37.0	-	225S	200	150	190	315	715	M20x400	450	170	450	820	570	710	365	550	115	1920	1150	1695	285	1010	760	710	365	570	110	2100	1300	1880	330	200	
150-500.1	30.0	-	225M	200	150	190	315	715	M20x400	450	170	450	820	570	710	365	550	115	1920	1150	1695	285	1010	760	710	365	570	110	2100	1300	1880	330	200	
150-500.1	37.0	-	250M	200	150	190	315	715	M20x400	450	170	450	900	650	605	313	550	110	2000	1250	1780	280	1110	860	810	415	590	110	2260	1450	2040	330	200	
150-500.1	45.0	-	280S	200	150	190	315	715	M20x400	450	170	450	900	650	605	313	550	110	2000	1250	1780	280	1110	860	810	415	590	110	2260	1450	2040	330	200	
150-500.1	-	75.0	280S	200	150	190	315	715	M20x400	450	170	450	900	650	605	313	550	110	2000	1250	1780	280	1110	860	810	415	590	110	2260	1450	2040	330	200	
150-500.1	55.0	90.0	280M	200	150	190	315	715	M20x400	450	170	450	1010	760	710	365	570	110	2100	1300	1880	330	1110	860	810	415	590	110	2260	1450	2040	330	200	
150-500.1	75.0	110.0	315S	200	150	190	315	715	M20x400	450	170	450	1010	760	710	365	570	110	2100	1300	1880	330	1110	860	800	410	610	110	2450	1650	2230	825	330	200
150-500.1	-	132.0	315M	200	150	190	315	715	M20x400	450	170	450	1110	860	810	415	590	110	2260	1450	2040	330	1110	860	800	410	610	110	2450	1650	2230	825	330	200

 1) DN = EN 1092-2/DN.../PN 10/21/GJL-250/B710  
 DN = EN 1092-2/DN.../PN 16/21/GJS-400-18-LT/B

Etanorm

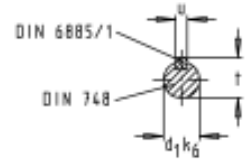
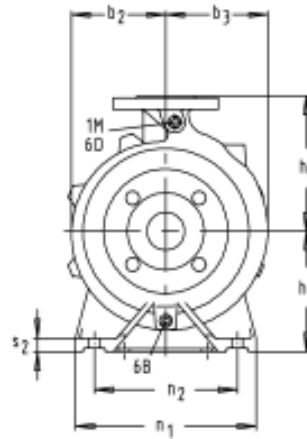
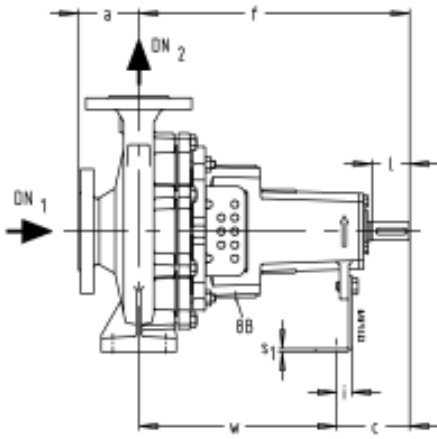

Etanorm G, M, S, B

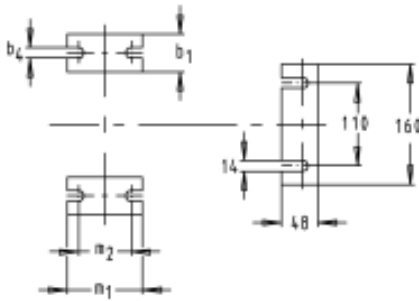

Etanorm C

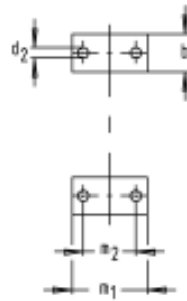

	DN 32-150	DN 200
Etanorm G, M	EN 1092-2/ PN 16/21/JL 1040/B	
Etanorm S	EN 1092-2/PN 16/21/JS 1025/B	
Etanorm B	ISO 7005-3/ PN 10/ 21	
Etanorm C	EN 1092-1	
	PN 16/21	PN 10/21

- 1 M Манометр - вывод для подключение
- 6 B Перекачиваемая жидкость - сливное отверстие
- 6 D Перекачиваемая жидкость - отверстие для заливки и выпуска воздуха
- 8 B Утечки жидкости - сток

Размеры в мм

Etanorm	DN <sub>1</sub>	DN <sub>2</sub>	a	b <sub>1</sub>	b <sub>2</sub>	b <sub>3</sub>	b <sub>4</sub>	c	d <sub>1</sub> ,k <sub>6</sub>	d <sub>2</sub>	f	h <sub>1</sub>	h <sub>2</sub>	i	l	m <sub>1</sub>	m <sub>2</sub>	n <sub>1</sub>	n <sub>2</sub>	s <sub>1</sub>	s <sub>2</sub>	t	u	w	Etanorm			
																									G, M, B		S, C	
																									1 M	8 B	1 M	8 B
32-125.1	50	32	80	50	113	113	14	100	24	-	360	112	140	23	50	100	70	190	140	4	15	27	8	260	Rc 3/8	G 1/2	G 3/8	G 1/2
32-160.1	50	32	80	50	116	125	14	100	24	14	360	132	160	23	50	100	70	240	190	4	15	27	8	260	Rc 3/8	G 1/2	G 3/8	G 1/2
32-200.1	50	32	80	50	128	137	14	100	24	14	360	160	180	25	50	100	70	240	190	6	18	27	8	260	Rc 3/8	G 1/2	G 3/8	G 1/2
32-250.1	50	32	100	65	164	171	14	100	24	14	360	180	225	25	50	125	95	320	250	6	18	27	8	260	Rc 3/8	G 1/2	G 3/8	G 1/2
32-125	50	32	80	50	113	113	14	100	24	14	360	112	140	23	50	100	70	190	140	4	15	27	8	260	Rc 3/8	G 1/2	G 3/8	G 1/2
32-160	50	32	80	50	113	125	14	100	24	14	360	132	160	23	50	100	70	240	190	4	15	27	8	260	Rc 3/8	G 1/2	G 3/8	G 1/2
32-200	50	32	80	50	132	141	14	100	24	14	360	160	180	25	50	100	70	240	190	6	18	27	8	260	Rc 3/8	G 1/2	G 3/8	G 1/2
32-250	50	32	100	65	170	176	14	100	24	14	360	180	225	25	50	125	95	320	250	6	18	27	8	260	Rc 3/8	G 1/2	G 3/8	G 1/2
40-125	65	40	80	50	113	113	14	100	24	14	360	112	140	23	50	100	70	210	160	4	15	27	8	260	Rc 3/8	G 1/2	G 3/8	G 1/2
40-160	65	40	80	50	115	131	14	100	24	14	360	132	160	23	50	100	70	240	190	4	15	27	8	260	Rc 3/8	G 1/2	G 3/8	G 1/2
40-200	65	40	100	50	115	131	14	100	24	14	360	160	180	25	50	100	70	265	212	6	18	27	8	260	Rc 3/8	G 1/2	G 3/8	G 1/2
40-250	65	40	100	65	165	178	14	100	24	14	360	180	225	25	50	125	95	320	250	6	18	27	8	260	Rc 3/8	G 1/2	G 3/8	G 1/2
40-315	65	40	125	65	194	203	14	130	32	14	470	225	250	24	80	125	95	345	280	6	18	35	10	340	Rc 3/8	G 1/2	G 3/8	G 1/2
50-125	65	50	100	50	113	128	14	100	24	14	360	132	160	23	50	100	70	240	190	4	18	27	8	260	Rc 3/8	G 1/2	G 3/8	G 1/2
50-160	65	50	100	50	126	147	14	100	24	14	360	160	180	25	50	100	70	265	212	6	18	27	8	260	Rc 3/8	G 1/2	G 3/8	G 1/2
50-200	65	50	100	50	145	165	14	100	24	14	360	160	200	25	50	100	70	265	212	6	18	27	8	260	Rc 3/8	G 1/2	G 3/8	G 1/2
50-250	65	50	100	65	168	184	14	100	24	14	360	180	225	25	50	125	95	320	250	6	18	27	8	260	Rc 3/8	G 1/2	G 3/8	G 1/2
50-315	65	50	125	65	200	216	14	130	32	14	470	225	280	24	80	125	95	345	280	6	18	35	10	340	Rc 3/8	G 1/2	G 3/8	G 1/2
65-125	80	65	100	65	120	148	14	100	24	14	360	160	180	25	50	125	95	280	212	6	18	27	8	260	Rc 3/8	G 1/2	G 3/8	G 1/2
65-160	80	65	100	65	130	158	14	100	24	14	360	160	200	25	50	125	95	280	212	6	18	27	8	260	Rc 3/8	G 1/2	G 3/8	G 1/2
65-200	80	65	100	65	154	177	14	100	24	14	360	180	225	25	50	125	95	320	250	6	18	27	8	260	Rc 3/8	G 1/2	G 3/8	G 1/2
65-250	80	65	100	80	180	200	19	130	32	18	470	200	250	24	80	160	120	360	280	6	20	35	10	340	Rc 3/8	G 1/2	G 3/8	G 1/2
65-315	80	65	125	80	208	229	19	130	32	18	470	225	280	24	80	160	120	400	315	6	20	35	10	340	Rc 3/8	G 1/2	G 3/8	G 1/2
80-160	100	80	125	65	153	192	14	100	24	14	360	180	225	25	50	125	95	320	250	6	18	27	8	260	Rc 3/8	G 1/2	G 3/8	G 1/2
80-200	100	80	125	65	161	189	14	130	32	14	470	180	250	24	80	125	95	345	280	6	18	35	10	340	Rc 3/8	G 1/2	G 3/8	G 1/2
80-250	100	80	125	80	184	210	19	130	32	18	470	200	280	24	80	160	120	400	315	6	18	35	10	340	Rc 3/8	G 1/2	G 3/8	G 1/2
80-315	100	80	125	80	220	244	19	130	32	18	470	250	315	24	80	160	120	400	315	6	20	35	10	340	Rc 3/8	G 1/2	G 3/8	G 1/2
80-400	100	80	125	80	253	276	19	160	42	18	530	280	355	25	110	160	120	435	355	6	20	45	12	370	Rc 3/8	G 1/2	G 3/8	G 1/2
100-160	125	100	125	80	178	225	19	130	32	18	470	200	280	24	80	160	120	360	280	6	18	35	10	340	Rc 1/2	G 1/2	G 1/2	G 1/2
100-200	125	100	125	80	173	213	19	130	32	18	470	200	280	24	80	160	120	360	280	6	18	35	10	340	Rc 1/2	G 1/2	G 1/2	G 1/2
100-250	125	100	140	80	190	220	19	130	32	18	470	225	280	24	80	160	120	400	315	6	18	35	10	340	Rc 1/2	G 1/2	G 1/2	G 1/2
100-315	125	100	140	80	225	255	19	130	32	18	470	250	315	24	80	160	120	400	315	6	18	35	10	340	Rc 1/2	G 1/2	G 1/2	G 1/2
100-400	125	100	140	100	253	280	24	160	42	26	530	280	355	25	110	200	150	500	400	6	20	45	12	370	Rc 1/2	G 1/2	G 1/2	G 1/2
125-200	150	125	140	80	195	244	19	130	32	18	470	250	315	24	80	160	120	400	315	6	20	35	10	340	Rc 1/2	G 1/2	G 1/2	G 1/2
125-250	150	125	140	80	226	275	19	130	32	18	470	250	355	24	80	160	120	400	315	6	20	35	10	340	Rc 1/2	G 1/2	G 1/2	G 1/2
125-315	150	125	140	100	238	278	24	160	42	23	530	280	355	25	110	200	150	500	400	6	20	35	12	370	Rc 1/2	G 1/2	G 1/2	G 1/2
125-400	150	125	140	100	275	306	24	160	42	23	530	315	400	25	110	200	150	500	400	6	20	45	12	370	Rc 1/2	G 1/2	G 1/2	G 1/2
150-200	200	150	160	100	238	315	24	130	32	23	470	280	400	24	80	200	150	550	450	6	20	35	10	340	Rc 1/2	G 1/2	G 1/2	G 1/2
150-250	200	150	160	100	228	298	24	130	32	23	470	280	400	24	80	200	150	500	400	6	20	35	10	340	Rc 1/2	G 1/2	G 1/2	G 1/2
150-315	200	150	160	100	255	303	24	160	42	23	530	280	400	25	110	200	150	550	450	6	20	45	12	370	Rc 1/2	G 1/2	G 1/2	G 1/2
150-400	200	150	160	100	285	325	24	160	42	23	530	315	450	25	110	200	150	550	450	6	20	45	12	370	Rc 1/2	G 1/2	G 1/2	G 1/2

1) Rc = ISO 7/1  
2) G = ISO 228/1



## Etanorm-R

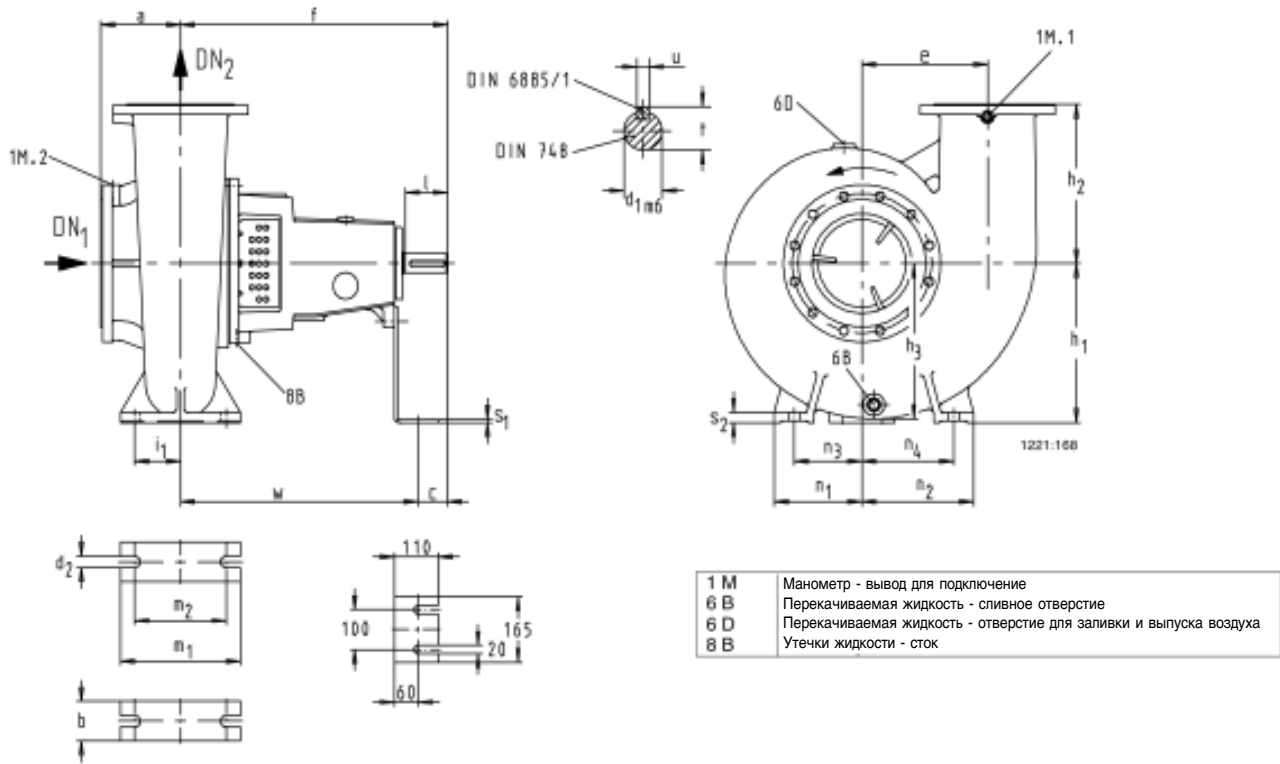

Размеры в мм

Etanorm-R	DN <sub>1</sub> <sup>1)</sup>	DN <sub>2</sub> <sup>1)</sup>	a	b	c	d <sub>1m6</sub>	d <sub>2</sub>	e	f	h <sub>1</sub>	h <sub>2</sub>	h <sub>3</sub>	i <sub>1</sub>	l	m <sub>1</sub>	m <sub>2</sub>	n <sub>1</sub>	n <sub>2</sub>	n <sub>3</sub>	n <sub>4</sub>	s <sub>1</sub>	s <sub>2</sub>	t	u	w
125-500/2	150	125	245	120	121	60	24	270	703	355	300	297	95	140	250	190	270	300	220	250	6	22	64	18	582
150-500.1	200	150	150	100	115	60	28	315	715	400	450	359	115	140	300	230	240	260	190	210	6	25	64	18	600
200-250	200	200	220	100	119	60	28	250	815	355	345	329	109	140	300	230	220	280	170	230	6	25	64	18	690
200-260	200	200	200	100	120	60	28	300	715	400	350	369	115	140	300	230	220	280	170	230	8	25	64	18	595
200-330	250	200	200	100	120	60	28	315	715	400	400	390	115	140	300	230	220	280	170	230	8	25	64	18	595
200-400	250	200	180	130	120	60	28	290	715	400	400	358	115	140	300	230	220	280	155	215	8	25	64	18	595
200-500	250	200	200	130	115	60	28	387	715	500	450	497	140	140	350	280	320	380	255	315	20	25	64	18	600
250-300	250	250	225	130	115	60	28	300	830	400	400	384	95	140	300	230	270	330	205	265	8	25	64	18	695
250-330	250	250	250	130	120	60	34	345	715	450	400	445	140	140	350	280	310	390	245	325	10	25	64	18	595
250-400	300	250	180	130	120	60	34	335	715	450	480	400	140	140	350	280	320	380	255	315	10	25	64	18	595
250-500	300	250	225	130	115	60	34	425	715	500	500	514	162.5	140	400	325	360	440	295	375	20	32	64	18	600
300-340	300	300	255	160	115	60	34	315	850	450	450	427	120	140	350	280	310	390	230	310	10	25	64	18	715
300-360	300	300	300	160	122	60	34	387	717	560	450	505	162.5	140	400	325	310	390	230	310	20	32	64	18	595
300-400	350	300	300	160	120	60	34	425	715	560	500	540	162.5	140	400	325	350	450	270	370	20	32	64	18	595
300-500	350	300	300	160	115	60	34	450	715	560	500	581	162.5	140	400	325	350	450	270	370	20	32	64	18	600

- 1) DN 125. 150 = EN 1092-2/DN.../PN 16/21/GJL-250/B  
 DN 200. 250. 300. 350 = EN 1092-2/DN.../PN 10/21/GJL-250/B  
 DN = EN 1092-2/DN.../PN 16/21/GJS-400-18-LT/B

**Etanorm**
**Взаимозаменяемость деталей насосов Etanorm и Etabloc и отдельных деталей друг с другом**

Etanorm	Узел вала	Наименование детали											
		Спиральный корпус	Крышка корпуса - сальниковое уплотнение	Крышка корпуса - торцовое уплотнение	Вал	Рабочее колесо	Радиальный шарикоподшипник	Торцовое уплотнение	Сальниковое уплотнение	Шелевое кольцо со стороны всаса	Шелевое кольцо с напорной стороны	Втулка вала	Защитная втулка вала
		102	163.1	163.2	210	230	321	433	461	502.1	502.2	523	524
32-125.1	25	○	1	12	1	○	1	1	1	1	X	1	1
32-160.1	25	○	1	12	1	1	1	1	1	1	3	1	1
32-200.1	25	○	4	15	1	2	1	1	1	1	3	1	1
32-250.1	25	○	6	17	1	3	1	1	1	1	4	1	1
32-125	25	○	1	12	1	○	1	1	1	1	X	1	1
32-160	25	○	1	12	1	1	1	1	1	1	3	1	1
32-200	25	○	4	15	1	2	1	1	1	1	3	1	1
32-250	25	○	6	17	1	3	1	1	1	1	4	1	1
40-125	25	○	1	12	1	○	1	1	1	2	X	1	1
40-160	25	○	1	12	1	○	1	1	1	2	3	1	1
40-200	25	○	4	15	1	○	1	1	1	○	3	1	1
40-250	25	○	6	17	1	○	1	1	1	2	4	1	1
40-315	35	○	○	○	2	○	2	2	2	2	13	2	2
50-125	25	○	1	12	1	○	1	1	1	3	3	1	1
50-160	25	○	1	12	1	○	1	1	1	3	3	1	1
50-200	25	○	4	15	1	○	1	1	1	3	3	1	1
50-250	25	○	6	17	1	○	1	1	1	3	4	1	1
50-315	35	○	9	20	2	○	2	2	2	5	10	2	2
65-125	25	○	1	12	1	○	1	1	1	5	3	1	1
65-160	25	○	2	13	1	○	1	1	1	5	9	1	1
65-200	25	○	○	○	1	○	1	1	1	5	9	1	1
65-250	35	○	○	○	2	○	2	2	2	9	13	2	2
65-315	35	○	9	20	2	○	2	2	2	9	10	2	2
80-160	25	○	2	13	1	○	1	1	1	6	9	1	1
80-200	35	○	3	14	2	○	2	2	2	6	10	2	2
80-250	35	○	7	18	2	○	2	2	2	6	10	2	2
80-315	35	○	9	20	2	○	2	2	2	6	10	2	2
80-400	55	○	11	22	3	○	3	3	3	10	8	3	3
100-160	35	○	3	14	2	○	2	2	2	7	10	2	2
100-200	35	○	3	14	2	○	2	2	2	7	10	2	2
100-250	35	○	7	18	2	○	2	2	2	7	10	2	2
100-315	35	○	9	20	2	○	2	2	2	7	10	2	2
100-400	55	○	11	22	3	○	3	3	3	7	8	3	3
125-200	35	○	5	16	2	○	2	2	2	8	11	2	2
125-250	35	○	8	19	2	○	2	2	2	8	14	2	2
125-315	55	○	10	21	3	○	3	3	3	8	8	3	3
125-400	55	○	11	22	3	○	3	3	3	8	8	3	3
150-200	35	○	5	16	2	○	2	2	2	○	11	2	2
150-250	35	○	8	19	2	○	2	2	2	12	14	2	2
150-315	55	○	10	21	3	○	3	3	3	12	8	3	3
150-400	55	○	11	22	3	○	3	3	3	12	8	3	3

1
1

Одинаковое число обозначает одинаковую деталь



Различные детали



Деталь не имеется в наличии



Деталь взаимозаменяема с Etabloc

**Etanorm-R**
**Взаимозаменяемость деталей насосов**

Etanorm-R	Узел вала	Наименование детали															
		Спиральный корпус	Вал	Рабочее колесо	Радиальный шарикоподшипник	Радиальное уплотнительное кольцо	Торцовое уплотнение	Крышка корпуса (для сальникового или торцового уплотнения)	Сальниковое уплотнение	Кольцо	Кольцо	Щелевое кольцо со стороны всаса	Щелевое кольцо с напорной стороны	Разбрызгивающее кольцо	Втулка вала	Защитная втулка вала	Распорная втулка
		Номер детали															
		102	210	230	321	411.4	433	451	461	500.1	500.3	502.1	502.2	507	523	524	525
125-500/2	65	○	○	○	1	1	1	○	1	1	1	○	○	1	○	○	○
150-500.1	65	○	1	○	1	1	1	1	1	1	1	1	1	1	1	1	x
200-250	65	○	2	○	1	1	1	○	1	1	1	○	3	1	2	2	x
200-260	65	○	1	○	1	1	1	○	1	1	1	1	3	1	1	1	x
200-330	65	○	1	○	1	1	1	4	1	1	1	○	4	1	1	1	x
200-400	65	○	1	○	1	1	1	○	1	1	1	2	2	1	1	1	x
200-500	65	○	1	○	1	1	1	1	1	1	1	○	1	1	1	1	x
250-300	65	○	2	○	1	1	1	4	1	1	1	○	4	1	2	2	x
250-330	65	○	1	○	1	1	1	○	1	1	1	2	4	1	1	1	x
250-400	65	○	1	○	1	1	1	○	1	1	1	○	1	1	1	1	x
250-500	65	○	1	○	1	1	1	2	1	1	1	○	1	1	1	1	x
300-340	65	○	2	○	1	1	1	○	1	1	1	○	2	1	2	2	x
300-360	65	○	1	○	1	1	1	3	1	1	1	○	1	1	1	1	x
300-400	65	○	1	○	1	1	1	3	1	1	1	3	1	1	1	1	x
300-500	65	○	1	○	1	1	1	2	1	1	1	3	1	1	1	1	x

 Различные детали

1
1

Одинаковое число обозначает одинаковую деталь

Деталь не имеется в наличии

**Etanorm**
**Рекомендуемое количество резервных деталей для 2-летней эксплуатации согласно DIN 24 296**

Номер детали	Наименование детали	Количество насосов (включая резервные)							
		2	3	4	5	6 и 7	8 и 9	10 и более	
Для исполнения с торцовым уплотнением		Количество запасных деталей (шт.)							
210	Вал	1	1	1	2	2	2	20 %	
230	Рабочее колесо (вкл. щелевое кольцо 502.2)	1	1	1	2	2	2	20 %	
321	Радиальный шарикоподшипник	2	2	4	4	6	8	100 %	
330	Корпус подшипника	-	-	-	-	-	1	2 шт.	
412	Уплотнительное кольцо круглого сечения	4	6	8	8	9	10	100 %	
433	Торцовое уплотнение	1	1	2	2	2	3	25 %	
502.1/2	Щелевое кольцо	2	2	2	3	3	4	50%	
523	Втулка вала	1	1	2	2	2	3	25 %	
---	Плоские уплотнения (комплект)	4	6	8	8	9	12	150 %	
---	Муфтовый передаточный элемент	1	1	2	2	3	4	30 %	
Для исполнения с сальниковым уплотнением									
461	Сальниковое уплотнение (компл.)	} При этом исключаются детали 412, 431, 523	4	4	6	6	6	8	100 %
524	Защитная втулка вала		2	2	2	3	3	4	50 %

**Etanorm-R**
**Рекомендуемое количество резервных деталей для 2-летней эксплуатации согласно DIN 24 296**

Номер детали	Наименование детали	Количество насосов (включая резервные)							
		2	3	4	5	6 и 7	8 и 9	10 и более	
Для исполнения с торцовым уплотнением		Количество запасных деталей (шт.)							
171	Ведущее колесо 1)	1	1	1	2	2	2	20 %	
210	Вал	1	1	1	2	2	2	20 %	
230	Рабочее колесо 2)	1	1	1	2	2	2	20 %	
321	Радиальный шарикоподшипник	2	2	4	4	4	6	50 %	
330	Корпус подшипника	-	-	-	-	-	1	2 шт.	
400./...	Плоские уплотнения (комплект)	4	6	8	8	9	12	150 %	
412	Уплотнительное кольцо круглого сечения 1)	4	6	8	8	9	12	150 %	
433	Торцовое уплотнение	1	1	2	2	2	3	25 %	
456	Опорная втулка	1	1	2	2	2	3	30 %	
500.1	Кольцо	4	4	8	8	8	12	100 %	
500.3	Кольцо	1	1	2	2	2	3	25 %	
502.1/2	Щелевое кольцо	2	2	2	3	3	4	50 %	
523	Втулка вала	2	2	2	3	3	4	50 %	
525	Распорная втулка 1)	1	1	1	2	2	2	20 %	
---	Муфтовый передаточный элемент	1	1	2	2	3	4	30 %	
Для исполнения с сальниковым уплотнением									
461	Сальниковое уплотн. (компл.)	} При этом исключаются детали 400.3, 433, 500.3, 523	4	4	6	6	6	8	180 %
524	Защитная втулка вала		2	2	2	3	3	4	50 %

1) Только для Etanorm-R 125-500/2

2) Для Etanorm-R 125-500/2 удвоенное количество детали

Возможны технические изменения

20.08.2004

1211-5/9