

## ► Air Cooled Water Chillers

**AQL** (Cooling Only Version)

**AQH** (Heat Pump Version)

**Models 20 to 35**



19.1 to 35.9 kW



20.5 to 38.6 kW



Engineering Data Manual

EDM AQ410-A.1GB

Date : September 2007

Supersedes : None

*Airwell*

# Key Points

---

- R410A refrigerant.
- Simpler refrigerant circuit layout.
- Great accessibility to internal components for service operations.
- New display on external panel allowing the complete control of the unit.
- Sight glass inspection hole allowing to check the sight glass without removing any panel.
- Operating limits of the unit stored in the flash memory of the control logic.
- Wide operating limits.
- High temperature operation up to 50 °C.
- Less noisy compared to the unit with R407C.
- Pump equipped as standard.
- "No pump" kit (accessory) that allows to switch from a pump equipped unit to a no pump unit.
- New gauge kit, easier to install.
- Fan speed control (accessory) for low ambient operation in cooling mode.
- Units are suitable for low water temperature applications with leaving water temperature of -8 °C (min.).
- ModBus interface.
- Phase sequence monitor supplied as standard.
- User-friendly microprocessor based control.
- ILTC (Intelligent Liquid Temperature Control) controller that allows to reduce the use of an external water tank.
- Return and leaving water temperature control logic.
- For safety during service operations, special valves dedicated to R 410A are available on the refrigerant system. These valves, of 5/16" flare SAE type, are mounted on the liquid line inside and on the lateral panel of the unit. This facilitates the access to the high and low sides of the refrigerant circuit in order to do pressure measurement.
- Double water set point.
- Rubber pads supplied as standard.
- Water filter supplied as standard.

## Specifications

---

### General

---

The new **Aqu@Logic** air cooled water chillers have been designed and optimized to operate with **R410A** refrigerant fluid. They are available in **cooling only (AQL)** and **heat pump (AQH)** versions.

Each version consists of **4 sizes** and covers a nominal cooling capacity range from **19.1 to 35.9 kW** and a nominal heating capacity range from **20.5 to 38.6 kW**.

All units are equipped with **two scroll compressors fitted in tandem** for adapting to partial system loads.

The general operation status of the machine is continuously under the control of an **ITLC** microprocessor based controller.

The AQL and AQH units can operate **without water tank**, thanks to the ILTC microprocessor that implements an **auto-adaptive control logic** ensuring a total protection of the compressors at different load or water volume conditions. The minimum water volume requested is **2.5 l/kW**. However, an external water tank can be supplied as accessory for field installation.

All units have a **pump on board** as standard, but they can be supplied with a "no pump" kit as accessory which allows installers to remove the integrated pump in order to use an external pump.

A **fan speed controller** can be supplied loose as field-installed accessory to authorize the unit to operate in cooling mode at low ambient temperature (-10 °C min.).

### Standards compliance

---

The AQL/AQH units are in conformity with the following standards :

- ✓ Performance test : EN 12055
- ✓ Electrical safety : EN 60204-1
- ✓ Machine directive : 98/37/EEC
- ✓ Low voltage directive : 2006/95/ EEC
- ✓ EMC directive : 89/336/ EEC
- ✓ PED : 97/23/ EEC

### Cabinet

---

The cabinet is made of heavy gauge galvanized steel. **All galvanized steel components are individually painted** by a special painting process before the assembly of the unit. This painting system performs a homogeneous protection to the corrosion.

The painting is a polyester powder based type, coloured in **RAL 9001**.

The units are suitable for outdoor installation, directly on the building roof or at the ground level.

### Compressors

---

Each unit is equipped with two scroll compressors fitted on a rail and assembled together to form **tandem compressors**. The compressors are then mounted on rubber pads in order to eliminate noise and vibration transmissions.

The compressor motors have a direct start-up. Each motor is cooled by the refrigerant gas and is equipped with an overload protection.

A soft start system can be supplied as optional, whereas a **phase sequence monitor** is supplied as standard.

### Evaporator

---

The evaporator is consisting of a stainless steel plate heat exchanger insulated with closed cell synthetic foam. It is protected by a **35 W anti-freeze electric heater** to ensure a good protection against freezing at low ambient temperature (-10 °C min.) when the unit is switched off.

Maximum working pressure is 10 bar at water side and 46 bar at refrigerant side.

### Air cooled condenser coil

---

The condenser coil is composed of **internally grooved** copper tubes mechanically expanded into corrugated aluminium fins.

The air cooled condenser is supplied with a **grille** to protect the coil from shocks.

# Specifications (continued)

## Condenser fans

Each unit has two axial fans with 610 mm of diameter. The fans are placed directly in front of the coil in order to increase air flow and heat transfer between air and refrigerant. They are fitted with protective grilles.

The condenser fans have **2 speeds** : 630 rpm for normal operating conditions and 450 rpm for night mode in order to generate low noise levels.

The fan motors have IP54 grade and are equipped with a thermal overload protection.

A pressure actuated fan speed controller can be supplied as an option to allow the unit to operate in cooling mode at ambient temperature down to -10 °C.

## Refrigerant circuit

All units have one refrigerant circuit consisting of scroll compressors, plate heat exchanger, thermostatic expansion valve, 4-way reverse cycle valve (heat pump version only) and coil.

A hole is provided on one side of the unit in order to do inspection on refrigerant via a sight glass during service operations without removing any panel.

All refrigerant components are shown in the functional diagrams illustrated in the next pages, section "Refrigerant flow diagrams".

## Hydraulic circuit

All units are supplied with a **circulating pump** as standard. The head of the pump is insulated with 10 mm insulation to avoid condensation on it.

A **water filter** is also supplied as standard.

A safety valve and an expansion tank are located on the suction side of the pump. Both high and low pressure sides are equipped with 3/8" fittings which allow water to be drained and manometer to be connected during service operations.

Water connections are of 1" 1/2 male gas threaded type.

## Control panel

The control panel contains an electrical board with keyboard and display for the visualization of the operating parameters and alarms. This control panel is accessible from outside because it is placed on an external panel. A Plexiglas cover protects the control from external agent.

The AQL/AQH chillers are equipped with a microprocessor based control with ILTC logic that implements an intelligent control on either **entering water temperature** or **leaving water temperature**.

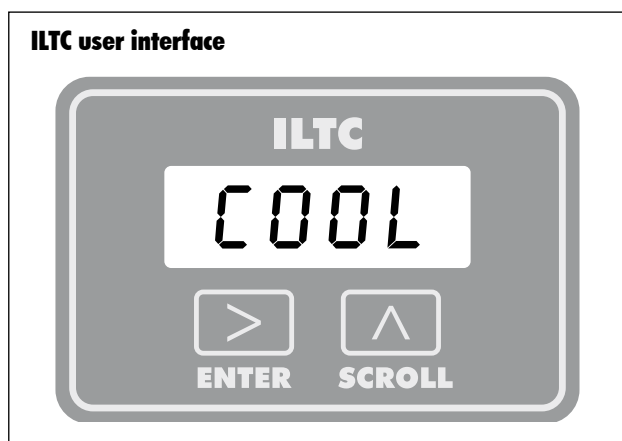

The main features of this control system are :

- User-friendly : with only 3 buttons and a tree logic, it is possible to control the unit easily,

- Reliable : all indications on the display are visible in every weather conditions,
- Test procedure,
- Night mode,
- Alarm visualization with a logging of the last 10 alarms,
- Remote ON/OFF switching,
- Compressors and pump working hour counter,
- Pressure transducers to control discharge and suction temperatures,
- Maximum discharge temperature control,
- Part load operating mode,
- Remote Cooling /Heating mode switching,
- Compatibility with BMS (ModBus protocol in RS485),
- Compressor operating limits stored in a flash memory.

## Safety and control devices

Each unit is complete with the following safety and control devices :

### Safety :

- Fan motor overload protection,
- Compressor motor overload protection,
- Water differential pressure switch,
- High pressure switch,
- High and low pressure transducers,
- Evaporator antifreeze electric heater,
- Crankcase oil electric heater.

### Control :

- Entering water temperature sensor,
- Leaving water temperature sensor,
- Coil temperature sensor,
- Discharge temperature sensor,
- Air temperature sensor,
- Suction and discharge pressure transducers.

## Factory-installed option

- Coil with blue fins
- Coil with "Fin Guard Silver" treatment
- Soft starter

## Field-installed accessories

- Fan speed control kit
- No pump kit
- Gauge kit
- Hydro kit 112 litres
- Flow switch
- In/out valve kit
- Remote On/Off control
- ModBus protocol kit for BMS
- Airconet protocol kit for BMS
- Power factor correction capacitors
- Sequencer for up to 4 chillers installation.

# Refrigerant Flow Diagram - AQL R410A

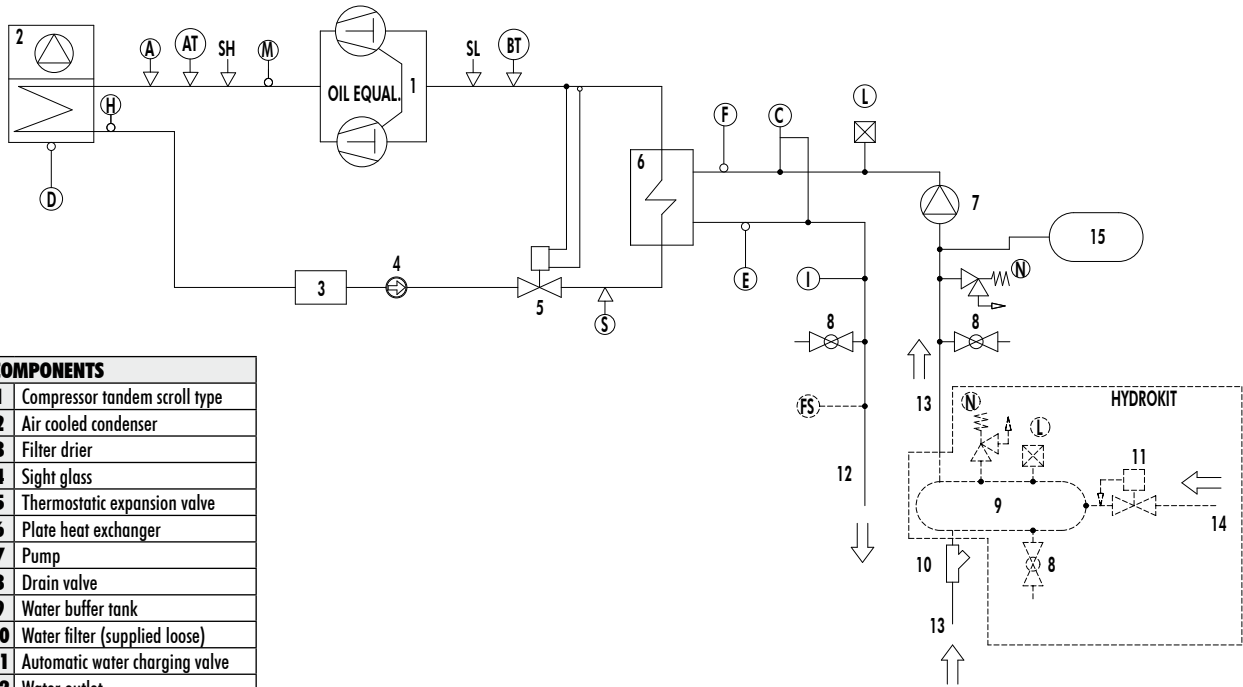

COMPONENTS	
1	Compressor tandem scroll type
2	Air cooled condenser
3	Filter drier
4	Sight glass
5	Thermostatic expansion valve
6	Plate heat exchanger
7	Pump
8	Drain valve
9	Water buffer tank
10	Water filter (supplied loose)
11	Automatic water charging valve
12	Water outlet
13	Water inlet
14	Water charging line
15	Pressure expansion tank

SAFETY/CONTROL DEVICES			
A	High pressure switch	H	Defrost temperature sensor
AT	High pressure transducer	I	Hydrometer
BT	Low pressure transducer	L	Vent valve
C	Water differential pressure switch	M	Discharge temperature sensor
D	Air temperature sensor	N	Water safety valve
E	Outlet water temperature sensor	S	5/16" Shrader valve (charging point)
F	Inlet water temperature sensor	SH	5/16" high pressure Shrader valve
FS	Flow switch	SL	5/16" low pressure Shrader valve

	Pipe connection with Shrader valve
	Optional parts

# Refrigerant Flow Diagram - AQH R410A

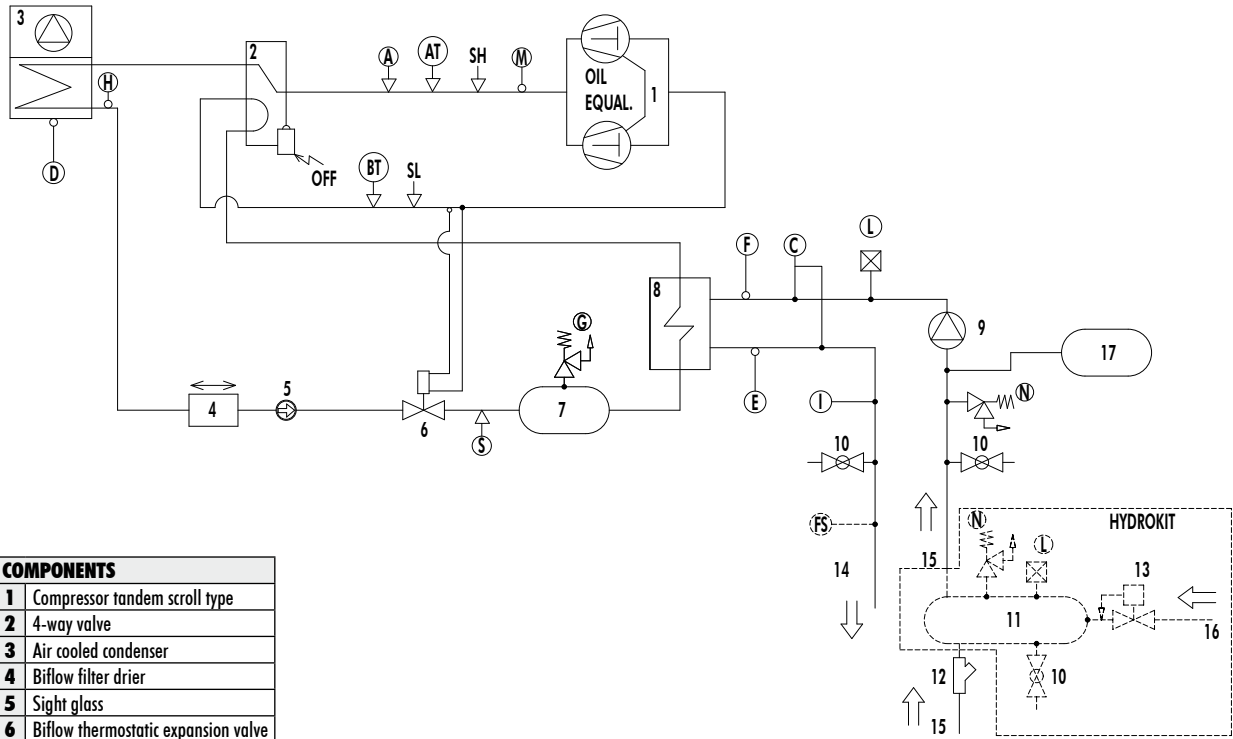

COMPONENTS	
1	Compressor tandem scroll type
2	4-way valve
3	Air cooled condenser
4	Biflow filter drier
5	Sight glass
6	Biflow thermostatic expansion valve
7	Liquid receiver
8	Plate heat exchanger
9	Pump
10	Drain valve
11	Water buffer tank
12	Water filter (supplied loose)
13	Automatic water charging valve
14	Water outlet
15	Water inlet
16	Water charging line
17	Pressure expansion tank

SAFETY/CONTROL DEVICES			
A	High pressure switch	H	Defrost temperature sensor
AT	High pressure transducer	I	Hydrometer
BT	Low pressure transducer	L	Vent valve
C	Water differential pressure switch	M	Discharge temperature sensor
D	Air temperature sensor	N	Water safety valve
E	Outlet water temperature sensor	S	5/16" Shradar valve (charging point)
F	Inlet water temperature sensor	SH	5/16" high pressure Shradar valve
FS	Flow switch	SL	5/16" low pressure Shradar valve
G	PED safety valve		

	Pipe connection with Shradar valve
-----	Optional parts

# Operating Limits

AQL/AQH in cooling mode		20		25		30		35			
		Min.	Max.	Min.	Max.	Min.	Max.	Min.	Max.		
Water	Water outlet temperature *	°C		-8	18	-8	18	-8	18	-8	18
	Water ΔT	K		3	8	3	8	3	8	3	8
	Flow rate	l/h		2050	5466	2676	7135	3318	8847	3858	10287
	Max. operating pressure	barg		3							
Air temperature **		°C		-10	50	-10	50	-10	50	-10	50
Optimal water volume		l		48		62		77		90	

\* Below 5 °C, glycol is required.

\*\* -10 °C is given for unit with fan speed controller (optional). Without fan speed controller, the limit is 10 °C.

AQH in heating mode		20		25		30		35			
		Min.	Max.	Min.	Max.	Min.	Max.	Min.	Max.		
Water	Water outlet temperature	°C		20	50	20	50	20	50	20	50
	Water ΔT	K		3	8	3	8	3	8	3	8
	Flow rate	l/h		2050	5466	2676	7135	3318	8847	3858	10287
	Max. operating pressure	barg		3							
Air temperature *		°C		-10	20	-10	20	-10	20	-10	20

\* Refer to diagram below.

## AQL/AQH in cooling mode

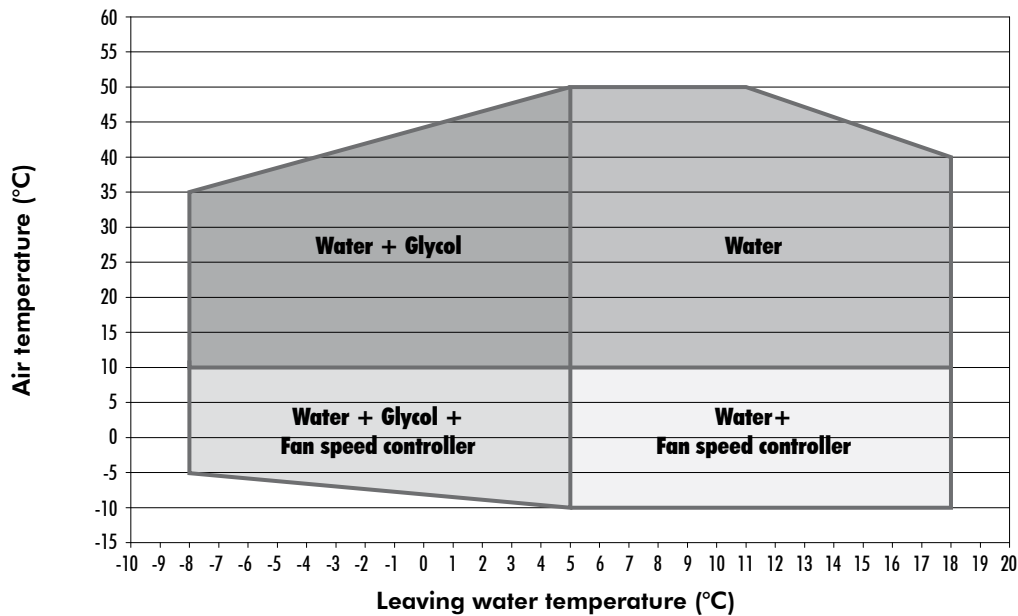

## AQH in heating mode

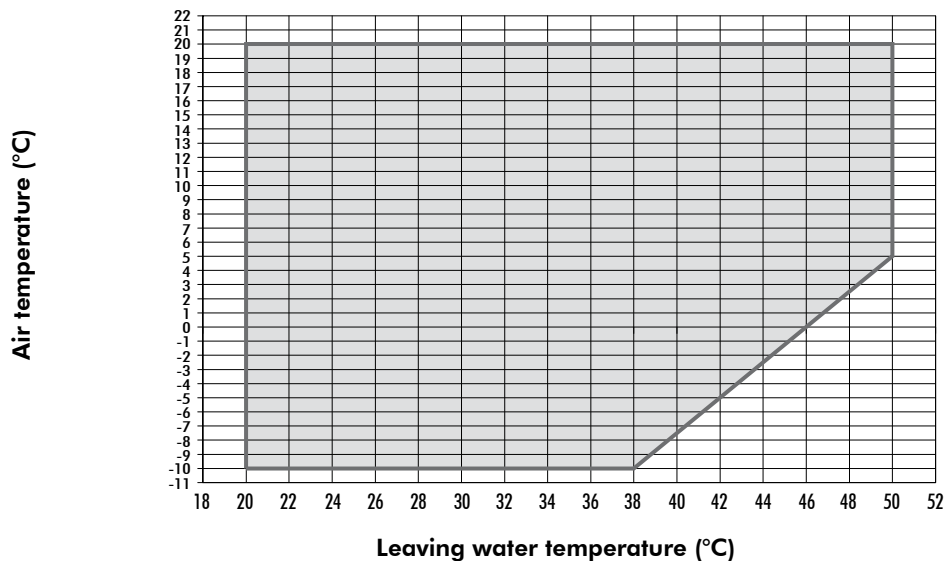

# Correction factors

---

## Fouling factors - Evaporator

Fouling factor (m <sup>2</sup> .°C/kW)	Cooling capacity factor	Power input factor
0.044	1.000	1.000
0.088	0.987	0.995
0.176	0.964	0.985
0.352	0.915	0.962

## Fouling factors - Condenser

Fouling factor (m <sup>2</sup> .°C/kW)	Cooling capacity factor	Power input factor
0.044	1.000	1.000
0.088	0.987	1.023
0.176	0.955	1.068
0.352	0.910	1.135

## Correction factors for water $\Delta T$ different from 5 K

Models	Water temperature in/out	Cooling capacity (kW)	Power input (kW)
AQL - AQH	17/7(10)	95%	98%
	14/7(7)	97%	99%
	12/7(5)	100%	100%
	10/7 (3)	103%	101%

## Altitude factors

Altitude (m)	Cooling capacity factor	Power input factor
0	1.000	1.000
600	0.987	1.010
1200	0.973	1.020
1800	0.958	1.030
2400	0.943	1.040

# Physical Data - AQL R410A

AQL SIZES		20	25	30	35
Cooling capacity	kW	19.1	24.9	30.9	35.9
Power input (compressor)	kW	5.5	7.5	10.0	11.2
Total EER*		3.13	3.06	2.93	3.0
Energy class		A	B	B	B
ESEER		5.00	4.94	4.37	4.08
IPLV		5.25	5.19	4.59	4.28
Number of refrigerant circuits		1	1	1	1
Part load steps	%	0-50-100	0-50-100	0-50-100	0-50-100
Power supply		400V/3+N/50Hz	400V/3+N/50Hz	400V/3+N/50Hz	400V/3+N/50Hz
Startup type		Direct	Direct	Direct	Direct
<b>REFRIGERANT</b>					
Type		R410A			
Charge	kg	5.1	7.0	7.0	7.8
<b>COMPRESSORS</b>					
Number		2	2	2	2
Type		Scroll	Scroll	Scroll	Scroll
Crankcase heater	W	70	70	70	70
<b>EVAPORATOR</b>					
Number		1	1	1	1
Type		Plate	Plate	Plate	Plate
Antifreeze heater	W	35	35	35	35
<b>COIL</b>					
Number		1	1	1	1
Frontal surface	l x h	986 x 1500	1350 x 1500	1350 x 1500	1350 x 1500
Number of rows		2	2	2	3
<b>FANS</b>					
Number		2	2	2	2
Air flow	m <sup>3</sup> /h	11300	13000	13000	12500
Speed	rpm	630	630	630	630
Power input	kW	0.6	0.6	0.6	0.6
<b>PUMP</b>					
Number		1	1	1	1
Power input	kW	Refer to corresponding performance curves			
Static head pressure	kPa	Refer to corresponding performance curves			
<b>WATER CONNECTIONS</b>					
Type		Male gas threaded			
Inlet diameter	inch	1" 1/2	1" 1/2	1" 1/2	1" 1/2
Outlet diameter	inch	1" 1/2	1" 1/2	1" 1/2	1" 1/2
Water drain connection	inch	3/8"	3/8"	3/8"	3/8"
<b>WEIGHT</b>					
Shipping	kg	279	297	304	318
Operating	kg	276	294	302	316
<b>DIMENSIONS</b>					
Length	mm	1477	1477	1477	1477
Width	mm	538	538	538	538
Height	mm	1625	1625	1625	1625
<b>ACOUSTICAL DATA (NORMAL MODE)</b>					
Sound power level	dB(A)	74	75	75	75
Sound pressure level at 10 metres	dB(A)	43	44	44	44

\* According to EN15411-1/2/3/4 (with compressors, fans, pump).



# Physical Data - AQH R410A

AQH SIZES		20	25	30	35
Cooling capacity	kW	19.1	24.9	30.9	35.9
Power input (compressor)	kW	5.5	7.5	10.0	11.2
Total EER*		3.13	3.06	2.93	3.01
Energy class		A	B	B	B
ESEER		5.00	4.94	4.37	4.08
IPLV		5.25	5.19	4.59	4.28
Heating capacity	kW	20.5	27.6	34.5	38.6
Power input (compressor)	kW	5.44	7.94	9.74	11.38
COP*		3.39	3.21	3.58	3.17
Number of refrigerant circuit		1	1	1	1
Part load steps	%	0-50-100	0-50-100	0-50-100	0-50-100
Power supply		400V/3+N/50Hz	400V/3+N/50Hz	400V/3+N/50Hz	400V/3+N/50Hz
Startup type		Direct	Direct	Direct	Direct
<b>REFRIGERANT</b>					
Type		R410A			
Charge	kg	5.1	7.0	7.0	7.8
<b>COMPRESSORS</b>					
Number		2	2	2	2
Type		Scroll	Scroll	Scroll	Scroll
Crankcase heater	W	70	70	70	70
<b>EVAPORATOR</b>					
Nombre		1	1	1	1
Type		Plate	Plate	Plate	Plate
Antifreeze heater	W	35	35	35	35
<b>COIL</b>					
Number		1	1	1	1
Surface frontale	l x h	986 x 1500	1350 x 1500	1350 x 1500	1350 x 1500
Number of rows		2	2	2	3
<b>FANS</b>					
Number		2	2	2	2
Air flow	m <sup>3</sup> /h	11300	13000	13000	12500
Speed	rpm	630	630	630	630
Power input	kW	0.6	0.6	0.6	0.6
<b>PUMP</b>					
Number		1	1	1	1
Power input	kW	Refer to corresponding performance curves			
Static head pressure	kPa	Refer to corresponding performance curves			
<b>WATER CONNECTIONS</b>					
Type		Male gas threaded			
Inlet diameter	inch	1" 1/2	1" 1/2	1" 1/2	1" 1/2
Outlet diameter	inch	1" 1/2	1" 1/2	1" 1/2	1" 1/2
Water drain connection	inch	3/8"	3/8"	3/8"	3/8"
<b>WEIGHT</b>					
Shipping	kg	292	310	318	333
Operating	kg	289	307	316	331
<b>DIMENSIONS</b>					
Length	mm	1477	1477	1477	1477
Width	mm	538	538	538	538
Height	mm	1625	1625	1625	1625
<b>ACOUSTICAL DATA (NORMAL MODE)</b>					
Sound power level	dB(A)	74	75	75	75
Sound pressure level at 10 metres	dB(A)	43	44	44	44

\* According to EN15411-1/2/3/4 (with compressors, fans, pump).

# Electrical Data

## Units\*

Sizes		20	25	30	35
Max. power input **	kW	10.1	13.6	15.8	18.0
Max. current input **	A	21.5	25.5	35.3	35.3
Start-up current	A	62	80	94	121

\* Data given for unit with one pump.

\*\* Data given for compressor at maximum conditions.

## Compressors

Sizes		Power input at max. conditions per compressor (kW)	Current at max. conditions per compressor FLA (A)	Startup current LRA (A)	Factor power nominal conditions	Crankcase heater (W)
20	COMP 1	4.3	8.0	48.0	0.78	70
	COMP 2	4.3	8.0	48.0	0.78	70
25	COMP 1	6.1	10.0	64.0	0.79	70
	COMP 2	6.1	10.0	64.0	0.79	70
30	COMP 1	7.2	15.0	74.0	0.84	70
	COMP 2	7.2	15.0	74.0	0.84	70
35	COMP 1	8.3	15.0	101.0	0.77	70
	COMP 2	8.3	15.0	101.0	0.77	70

## Fans (230V/1/50Hz)

Sizes	Number of fans	Nominal power per fan (kW)	Max. running current per fan (A)	Total fan power (kW)	Total max. fan current (A)
20	2	0.3	1.8	0.6	3.6
25	2	0.3	1.8	0.6	3.6
30	2	0.3	1.8	0.6	3.6
35	2	0.3	1.8	0.6	3.6

## Pump (400V/3/50Hz)

Sizes	Nominal power (kW)	Max. running current (A)
20	0.83	1.9
25	0.83	1.9
30	0.83	1.7
35	0.83	1.7

# Acoustical Data

## Sound power level - Lw dB(A) - Normal mode

AQL/AQH models	Frequency in octave band (Hz)								Lw(A) Total dB
	63	125	250	500	1000	2000	4000	8000	
20	71.1	78.8	73.5	71.7	68.9	66.7	58.0	48.0	<b>74</b>
25	70.3	85.9	72.4	72.0	70.2	65.6	57.1	49.5	<b>75</b>
30	72.0	75.4	74.2	72.6	70.2	67.1	59.5	51.6	<b>75</b>
35	72.9	76.2	74.4	73.2	70.7	65.2	58.6	48.2	<b>75</b>

## Sound pressure level - Lp dB(A) - Normal mode

AQL/AQH models	Frequency in octave band (Hz)								Lp(A) Total dB
	63	125	250	500	1000	2000	4000	8000	
20	39.6	47.3	42.0	40.2	37.4	35.2	26.5	16.5	<b>43</b>
25	38.8	54.4	40.9	40.5	38.7	34.1	25.6	18.0	<b>44</b>
30	40.5	43.9	42.7	41.1	38.7	35.6	28.0	20.1	<b>44</b>
35	41.4	44.7	42.9	41.7	39.2	33.7	27.1	16.7	<b>44</b>

## Sound power level - Lw dB(A) - Night mode

AQL/AQH models	Frequency in octave band (Hz)								Lw(A) Total dB
	63	125	250	500	1000	2000	4000	8000	
20	65.2	74.9	66.7	66.8	62.0	59.6	53.7	43.8	<b>68</b>
25	67.2	70.2	68.4	69.1	68.4	63.7	55.0	50.0	<b>72</b>
30	72.3	72.9	70.7	69.7	67.0	63.7	57.8	52.3	<b>72</b>
35	75.3	72.8	71.7	69.9	67.9	62.0	54.8	46.6	<b>72</b>

## Sound pressure level - Lp dB(A) - Night mode

AQL/AQH models	Frequency in octave band (Hz)								Lp(A) Total dB
	63	125	250	500	1000	2000	4000	8000	
20	33.7	43.4	35.2	35.3	30.5	28.1	22.2	12.3	<b>37</b>
25	35.7	38.7	36.9	37.6	36.9	32.2	23.5	18.5	<b>41</b>
30	40.8	41.4	39.2	38.2	35.5	32.2	26.3	20.8	<b>41</b>
35	43.8	41.3	40.2	38.4	36.4	30.5	23.3	15.1	<b>41</b>

Note : Sound pressure levels are calculated at a distance of 10 meters. Factor of direction Q=2. Tolerance 2dB.

# Performance Data - AQL R410A

AQL sizes	LWT (°C)	Ambient air temperature (°C)																	
		25		30		32		35		40		43		46		48		50	
		Cool. cap. (kW)	Input power* (kW)	Cool. cap. (kW)	Input power* (kW)	Cool. cap. (kW)	Input power* (kW)	Cool. cap. (kW)	Input power* (kW)	Cool. cap. (kW)	Input power* (kW)	Cool. cap. (kW)	Input power* (kW)	Cool. cap. (kW)	Input power* (kW)	Cool. cap. (kW)	Input power* (kW)	Cool. cap. (kW)	Input power* (kW)
AQL 20	5	20.1	4.5	19.1	4.9	18.7	5.1	18.0	5.4	16.9	5.9	16.2	6.3	15.4	6.6	15.0	6.9	14.5	7.2
	7	21.3	4.6	20.2	5.0	19.7	5.2	<b>19.1</b>	<b>5.5</b>	17.9	6.0	17.1	6.4	16.3	6.7	15.8	7.0	15.3	7.2
	9	22.4	4.6	21.3	5.1	20.8	5.3	20.1	5.6	18.9	6.1	18.1	6.5	17.3	6.8	16.7	7.1	16.2	7.3
	11	23.6	4.7	22.4	5.2	22.0	5.4	21.2	5.7	19.9	6.2	19.1	6.6	18.2	7.0	17.6	7.2	17.1	13.4
	13	24.8	4.8	23.6	5.3	23.1	5.5	22.3	5.8	21.0	6.3	20.1	15.7	19.3	7.1	18.6	7.3		
	15	26.1	4.9	24.8	5.4	24.3	5.6	23.5	5.9	22.1	6.4	21.1	16.5						
	17	27.4	5.0	26.1	5.5	25.5	5.7	24.6	6.0	23.2	6.5								
	18	27.9	5.1	26.6	5.5	26.0	5.7	25.1	6.0	23.6	6.6								
AQL 25	5	26.2	6.0	25.0	6.6	24.4	6.9	23.5	7.3	22.1	8.0	21.2	8.5	20.1	9.0	19.6	9.3	18.9	9.7
	7	27.8	6.2	26.3	6.8	25.7	7.0	<b>24.9</b>	<b>7.5</b>	23.4	8.1	22.3	8.6	21.3	9.1	20.7	9.4	20.0	9.8
	9	29.3	6.2	27.8	6.8	27.2	7.1	26.2	7.5	24.6	8.3	23.6	8.7	22.6	9.2	21.8	9.6	21.2	9.9
	11	30.8	6.4	29.3	7.0	28.7	7.2	27.7	7.7	26.0	8.4	24.9	8.9	23.8	9.4	23.0	9.8	22.3	18.0
	13	32.4	6.5	30.8	7.1	30.1	7.4	29.1	7.8	27.3	8.5	26.2	21.2	25.1	9.6	24.3	9.9		
	15	34.1	6.6	32.4	7.2	31.7	7.5	30.6	7.9	28.8	8.7	27.6	22.3						
	17	35.7	6.8	34.0	7.4	33.3	7.7	32.2	8.1	30.2	8.8								
	18	36.4	6.8	34.7	7.4	33.9	7.7	32.8	8.1	30.8	8.9								
AQL 30	5	32.5	8.1	31.0	8.9	30.2	9.3	29.2	9.8	27.4	10.8	26.2	11.4	25.0	12.1	24.2	12.5	23.4	13.1
	7	34.4	8.3	32.6	9.1	31.9	9.5	<b>30.9</b>	<b>10.0</b>	29.0	11.0	27.7	11.6	26.5	12.2	25.6	12.7	24.8	13.2
	9	36.3	8.4	34.4	9.2	33.7	9.6	32.5	10.1	30.5	11.1	29.3	11.8	28.0	12.4	27.1	13.0	26.2	13.3
	11	38.2	8.6	36.3	9.4	35.6	9.8	34.3	10.3	32.2	11.3	30.9	12.0	29.5	12.7	28.6	13.2	27.7	24.3
	13	40.2	8.7	38.2	9.6	37.4	9.9	36.1	10.5	33.9	11.5	32.5	28.5	31.2	12.9	30.1	13.3		
	15	42.3	8.9	40.2	9.8	39.3	10.1	38.0	10.7	35.7	11.7	34.2	30.0						
	17	44.3	9.1	42.2	9.9	41.3	10.3	39.9	10.9	37.5	11.9								
	18	45.2	9.2	43.0	10.0	42.0	10.4	40.7	10.9	38.2	12.0								
AQL 35	5	37.8	9.0	36.0	9.9	35.2	10.3	33.9	11.0	31.9	12.0	30.5	12.7	29.1	13.4	28.2	13.9	27.2	14.5
	7	40.0	9.2	38.0	10.1	37.1	10.5	<b>35.9</b>	<b>11.2</b>	33.7	12.2	32.2	12.9	30.8	13.6	29.8	14.1	28.8	14.6
	9	42.2	9.3	40.0	10.2	39.2	10.6	37.8	11.3	35.5	12.4	34.1	13.1	32.6	13.8	31.5	14.4	30.5	14.8
	11	44.4	9.5	42.2	10.4	41.4	10.9	39.9	11.5	37.5	12.6	35.9	13.3	34.3	14.1	33.2	14.6	32.2	27.0
	13	46.7	9.7	44.4	10.6	43.5	11.1	42.0	11.7	39.4	12.8	37.8	31.7	36.3	14.3	35.0	14.8		
	15	49.2	9.9	46.7	10.9	45.7	11.3	44.2	11.9	41.5	13.0	39.8	33.4						
	17	51.5	10.1	49.1	11.1	48.0	11.5	46.4	12.1	43.6	13.2								
	18	52.5	10.2	50.0	11.1	48.9	11.5	47.3	12.1	44.4	13.3								

\* Compressors only.  
LWT : Leaving water temperature.

# Performance Data - AQH R410A

## Cooling mode

AQH sizes	LWT (°C)	Ambient air temperature (°C)																	
		25		30		32		35		40		43		46		48		50	
		Cool. cap. (kW)	Input power* (kW)	Cool. cap. (kW)	Input power* (kW)	Cool. cap. (kW)	Input power* (kW)	Cool. cap. (kW)	Input power* (kW)	Cool. cap. (kW)	Input power* (kW)	Cool. cap. (kW)	Input power* (kW)	Cool. cap. (kW)	Input power* (kW)	Cool. cap. (kW)	Input power* (kW)	Cool. cap. (kW)	Input power* (kW)
AQH 20	5	20.1	4.5	19.1	4.9	18.7	5.1	18.0	5.4	16.9	5.9	16.2	6.3	15.4	6.6	15.0	6.9	14.5	7.2
	7	21.3	4.6	20.2	5.0	19.7	5.2	<b>19.1</b>	<b>5.5</b>	17.9	6.0	17.1	6.4	16.3	6.7	15.8	7.0	15.3	7.2
	9	22.4	4.6	21.3	5.1	20.8	5.3	20.1	5.6	18.9	6.1	18.1	6.5	17.3	6.8	16.7	7.1	16.2	7.3
	11	23.6	4.7	22.4	5.2	22.0	5.4	21.2	5.7	19.9	6.2	19.1	6.6	18.2	7.0	17.6	7.2	17.1	13.4
	13	24.8	4.8	23.6	5.3	23.1	5.5	22.3	5.8	21.0	6.3	20.1	15.7	19.3	7.1	18.6	7.3		
	15	26.1	4.9	24.8	5.4	24.3	5.6	23.5	5.9	22.1	6.4	21.1	16.5						
	17	27.4	5.0	26.1	5.5	25.5	5.7	24.6	6.0	23.2	6.5								
	18	27.9	5.1	26.6	5.5	26.0	5.7	25.1	6.0	23.6	6.6								
AQH 25	5	26.2	6.0	25.0	6.6	24.4	6.9	23.5	7.3	22.1	8.0	21.2	8.5	20.1	9.0	19.6	9.3	18.9	9.7
	7	27.8	6.2	26.3	6.8	25.7	7.0	<b>24.9</b>	<b>7.5</b>	23.4	8.1	22.3	8.6	21.3	9.1	20.7	9.4	20.0	9.8
	9	29.3	6.2	27.8	6.8	27.2	7.1	26.2	7.5	24.6	8.3	23.6	8.7	22.6	9.2	21.8	9.6	21.2	9.9
	11	30.8	6.4	29.3	7.0	28.7	7.2	27.7	7.7	26.0	8.4	24.9	8.9	23.8	9.4	23.0	9.8	22.3	18.0
	13	32.4	6.5	30.8	7.1	30.1	7.4	29.1	7.8	27.3	8.5	26.2	21.2	25.1	9.6	24.3	9.9		
	15	34.1	6.6	32.4	7.2	31.7	7.5	30.6	7.9	28.8	8.7	27.6	22.3						
	17	35.7	6.8	34.0	7.4	33.3	7.7	32.2	8.1	30.2	8.8								
	18	36.4	6.8	34.7	7.4	33.9	7.7	32.8	8.1	30.8	8.9								
AQH 30	5	32.5	8.1	31.0	8.9	30.2	9.3	29.2	9.8	27.4	10.8	26.2	11.4	25.0	12.1	24.2	12.5	23.4	13.1
	7	34.4	8.3	32.6	9.1	31.9	9.5	<b>30.9</b>	<b>10.0</b>	29.0	11.0	27.7	11.6	26.5	12.2	25.6	12.7	24.8	13.2
	9	36.3	8.4	34.4	9.2	33.7	9.6	32.5	10.1	30.5	11.1	29.3	11.8	28.0	12.4	27.1	13.0	26.2	13.3
	11	38.2	8.6	36.3	9.4	35.6	9.8	34.3	10.3	32.2	11.3	30.9	12.0	29.5	12.7	28.6	13.2	27.7	24.3
	13	40.2	8.7	38.2	9.6	37.4	9.9	36.1	10.5	33.9	11.5	32.5	28.5	31.2	12.9	30.1	13.3		
	15	42.3	8.9	40.2	9.8	39.3	10.1	38.0	10.7	35.7	11.7	34.2	30.0						
	17	44.3	9.1	42.2	9.9	41.3	10.3	39.9	10.9	37.5	11.9								
	18	45.2	9.2	43.0	10.0	42.0	10.4	40.7	10.9	38.2	12.0								
AQH 35	5	37.8	9.0	36.0	9.9	35.2	10.3	33.9	11.0	31.9	12.0	30.5	12.7	29.1	13.4	28.2	13.9	27.2	14.5
	7	40.0	9.2	38.0	10.1	37.1	10.5	<b>35.9</b>	<b>11.2</b>	33.7	12.2	32.2	12.9	30.8	13.6	29.8	14.1	28.8	14.6
	9	42.2	9.3	40.0	10.2	39.2	10.6	37.8	11.3	35.5	12.4	34.1	13.1	32.6	13.8	31.5	14.4	30.5	14.8
	11	44.4	9.5	42.2	10.4	41.4	10.9	39.9	11.5	37.5	12.6	35.9	13.3	34.3	14.1	33.2	14.6	32.2	27.0
	13	46.7	9.7	44.4	10.6	43.5	11.1	42.0	11.7	39.4	12.8	37.8	31.7	36.3	14.3	35.0	14.8		
	15	49.2	9.9	46.7	10.9	45.7	11.3	44.2	11.9	41.5	13.0	39.8	33.4						
	17	51.5	10.1	49.1	11.1	48.0	11.5	46.4	12.1	43.6	13.2								
	18	52.5	10.2	50.0	11.1	48.9	11.5	47.3	12.1	44.4	13.3								

## Heating mode

AQH sizes	LWT (°C)	Ambient air temperature (°C)													
		-5		-3		0		5		7		10		15	
		Heating cap. (kW)	Input power* (kW)	Heating cap. (kW)	Input power* (kW)	Heating cap. (kW)	Input power* (kW)	Heating cap. (kW)	Input power* (kW)	Heating cap. (kW)	Input power* (kW)	Heating cap. (kW)	Input power* (kW)	Heating cap. (kW)	Input power* (kW)
AQH 20	30	15.4	3.9	16.3	3.9	17.7	3.9	20.2	3.9	21.4	3.9	23.3	4.0	26.8	4.0
	35	15.3	4.4	16.1	4.4	17.5	4.4	20.0	4.4	21.1	4.4	22.9	4.4	26.3	4.5
	40	15.2	4.8	16.0	4.8	17.3	4.9	19.8	4.9	20.8	4.9	22.5	4.9	25.7	4.9
	45					17.2	5.4	19.5	5.4	<b>20.5</b>	<b>5.4</b>	22.1	5.4	25.2	5.5
	50							19.2	6.1	20.1	6.1	21.7	6.1	24.7	6.1
AQH 25	30	20.7	5.7	21.9	5.7	23.8	5.7	27.3	5.7	28.8	5.7	31.3	5.8	36.1	5.8
	35	20.6	6.3	21.7	6.3	23.6	6.3	26.9	6.3	28.4	6.4	30.8	6.4	35.4	6.5
	40	20.4	7.0	21.6	7.0	23.3	7.1	26.6	7.1	28.0	7.1	30.3	7.2	34.7	7.2
	45					23.2	7.9	26.2	7.9	<b>27.6</b>	<b>7.9</b>	29.8	7.9	33.9	8.0
	50							25.9	8.9	27.1	8.9	29.2	8.9	33.2	8.9
AQH 30	30	25.9	7.0	27.4	7.0	29.9	7.1	34.1	7.1	36.1	7.1	39.2	7.1	45.2	7.1
	35	25.8	7.8	27.2	7.8	29.5	7.8	33.7	7.8	35.6	7.9	38.6	7.9	44.3	8.0
	40	25.6	8.6	27.0	8.6	29.2	8.7	33.3	8.7	35.1	8.7	37.9	8.8	43.4	8.8
	45					29.0	9.7	32.8	9.7	<b>34.5</b>	<b>9.7</b>	37.3	9.7	42.5	9.8
	50							32.4	11.0	33.9	11.0	36.6	11.0	41.6	11.0
AQH 35	30	28.9	8.1	30.7	8.1	33.4	8.2	38.2	8.2	40.3	8.2	43.9	8.3	50.6	8.3
	35	28.8	9.1	30.4	9.1	33.1	9.1	37.7	9.1	39.8	9.2	43.2	9.2	49.6	9.3
	40	28.6	10.1	30.2	10.1	32.7	10.2	37.3	10.2	39.2	10.2	42.4	10.3	48.6	10.3
	45					32.5	11.4	36.7	11.4	<b>38.6</b>	<b>11.4</b>	41.7	11.4	47.5	11.5
	50							36.2	12.8	38.0	12.8	40.9	12.8	46.5	12.8

\* Compressors only.  
LWT : Leaving water temperature.

# Pump and Plate Heat Exchanger Curves - AQL/AQH R410A

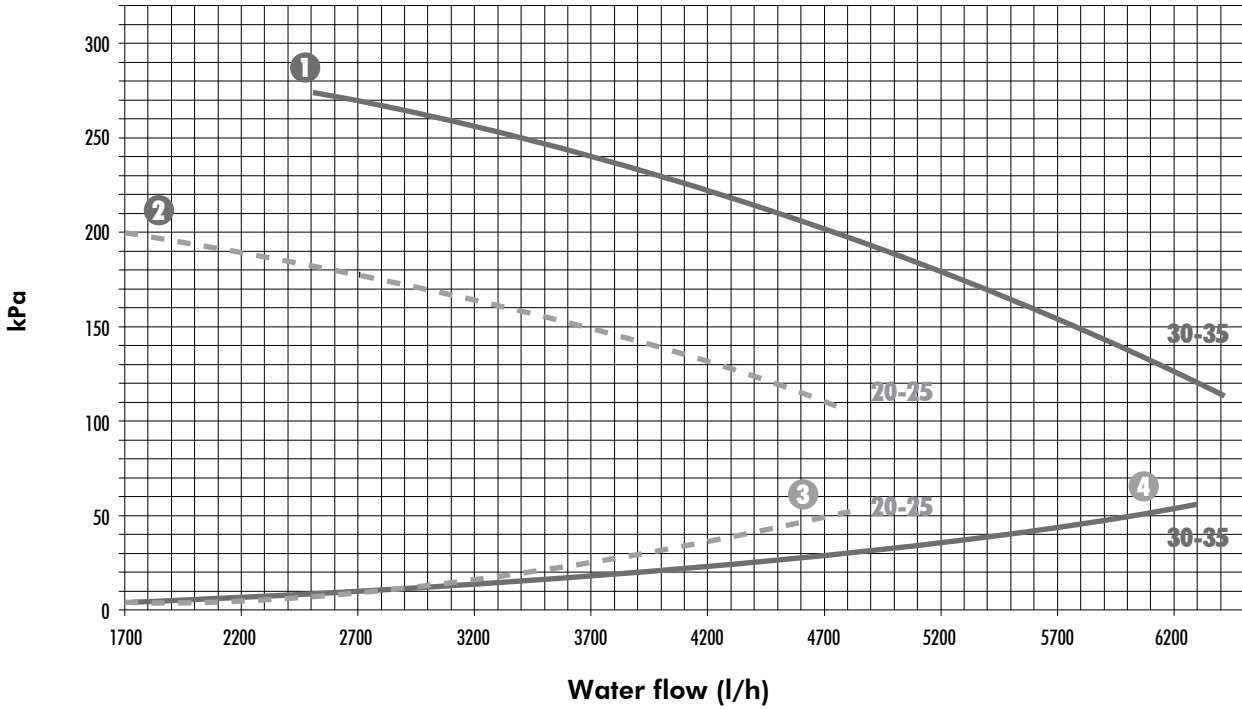

- ① and ② pump static head pressure curves.
- ③ and ④ plate heat exchanger water pressure drop curves.

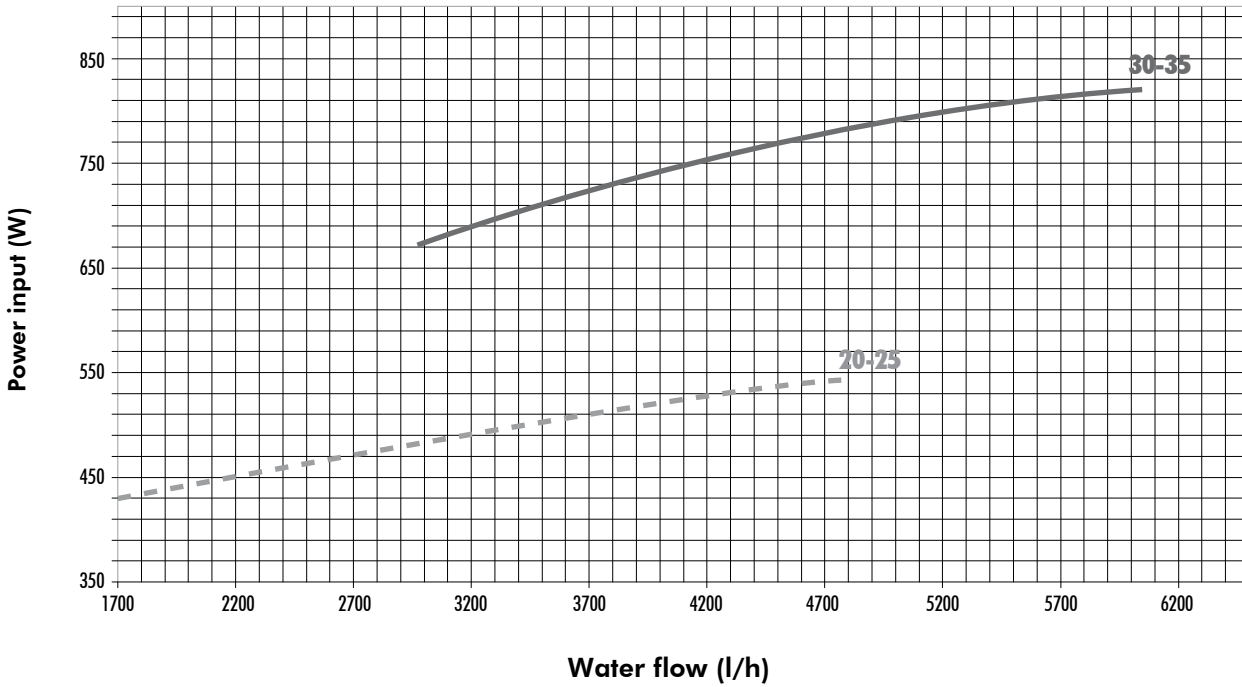

# Dimensions - AQL/AQH R410A 20 to 35

**Front view**

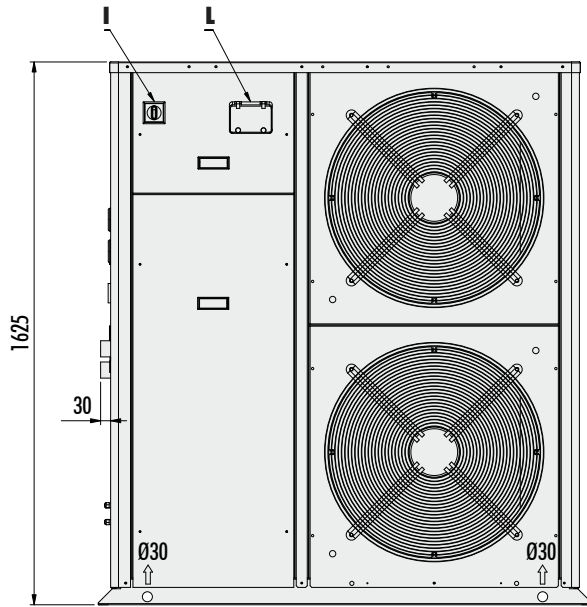

**Side view**

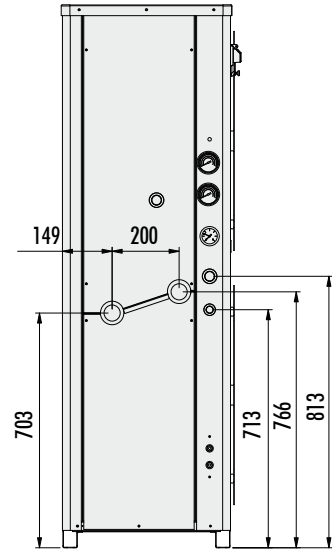

**Top view**

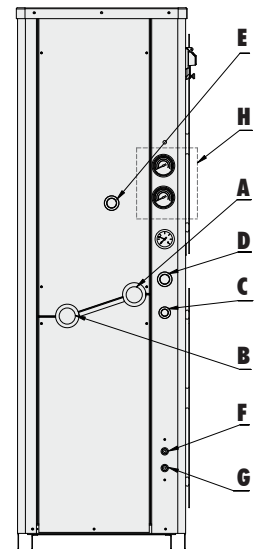
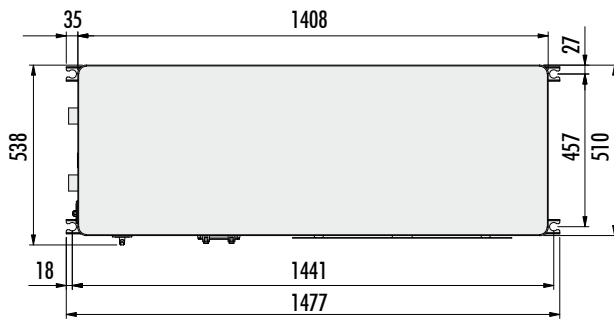

<b>A</b>	Water inlet Ø1 1/2" gas male
<b>B</b>	Water outlet Ø1 1/2" gas male
<b>C</b>	Auxiliary lines
<b>D</b>	Electrical power supply
<b>E</b>	Sight glass inspection
<b>F</b>	High pressure tap
<b>G</b>	Low pressure tap
<b>H</b>	Gauge kit (optional)
<b>I</b>	Main switch
<b>L</b>	Control keypad/display

Dimensions in mm.

# Dimensions - External Hydrokit for AQL/AQH R410A 20 to 35

**Front view**

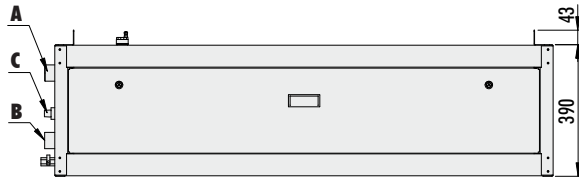

**Side view**

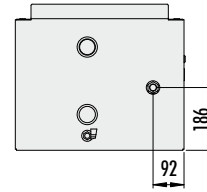

**Top view**

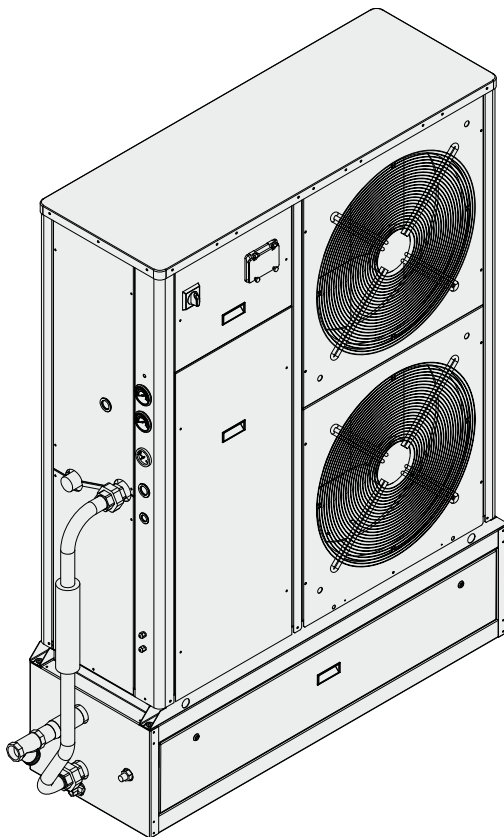
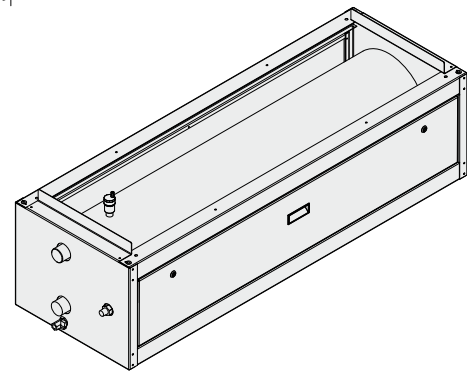
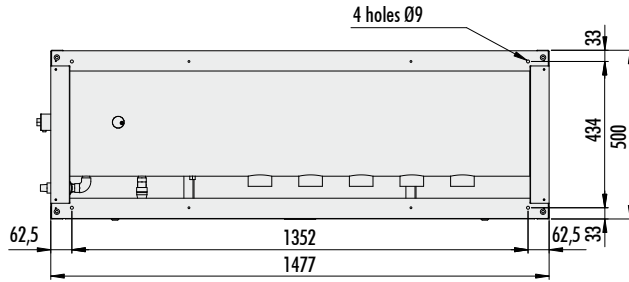

<b>A</b>	Water inlet Ø1 ½" gas male
<b>B</b>	Water outlet Ø1 ½" gas male
<b>C</b>	Tank fill Ø1/2" gas male

Dimensions in mm.

## Space requirements - AQL/AQH R410A 20-35

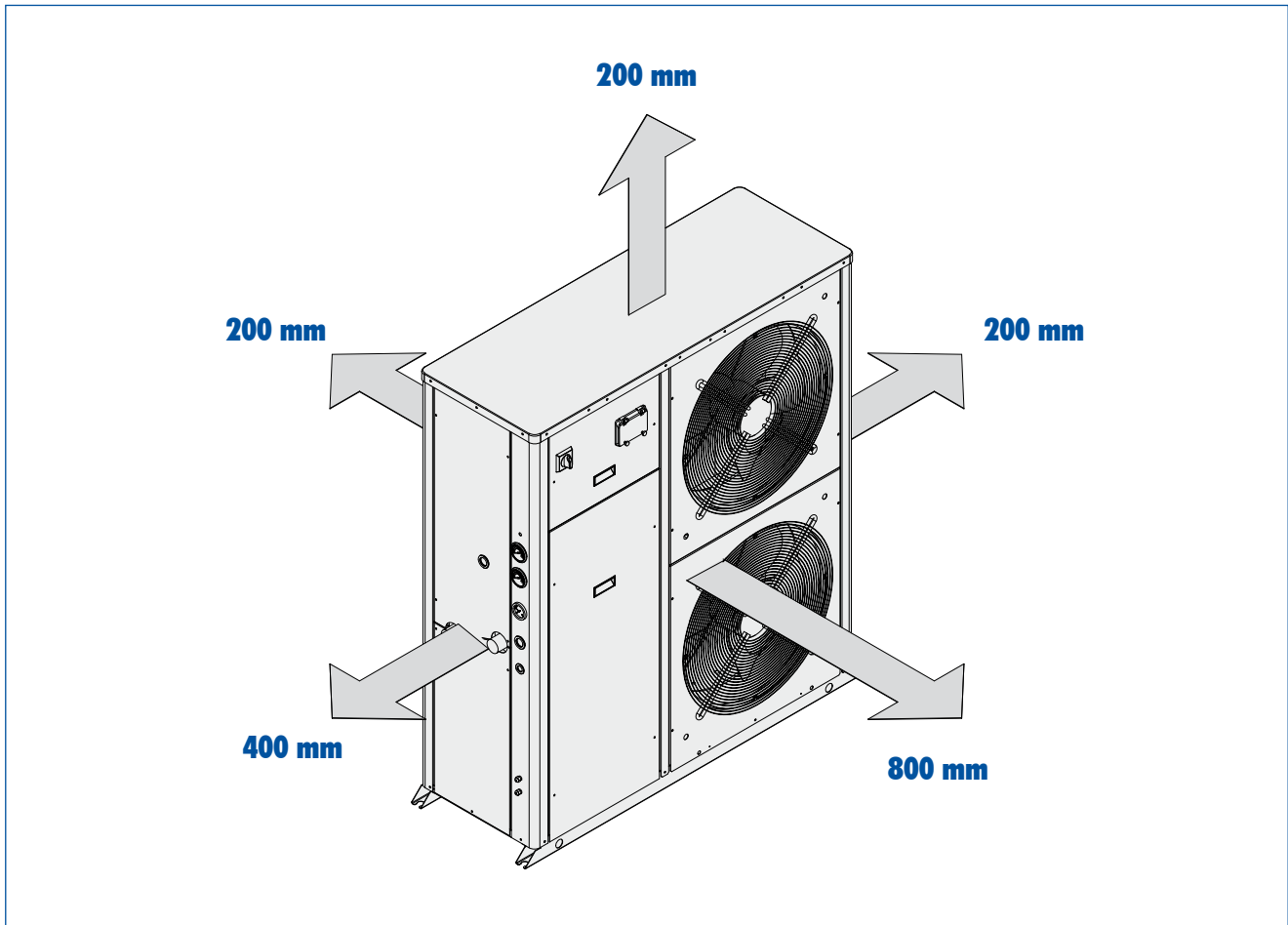

# Airwell

### ACE Marketing S.A.S.

CAC Export Department  
42 cours Jean-Jaurès  
17800 Pons - France  
Tel. : +33 (0)5 46 92 33 33 - Fax : +33 (0)5 46 91 26 44  
[www.airwell.com](http://www.airwell.com)

Your distributor :